

DKM20
TECHNICAL CATALOGUE
TEKNIK KATALOG

HYDRAULIC ^{GEAR} MOTORS





Ascend to Greater Value
Birlikte Daha Yüksekçe

 **blue**
ascend
hydraulics

blueascend.com

DKM20
TECHNICAL CATALOGUE
TEKNIK KATALOG

HYDRAULIC ^{GEAR} MOTORS

1. GENEL BİLGİLER

Blue Ascend dişli motorları yüksek mukavemetli alüminyum alaşım gövde ekstrüzyon/döküm ve üç ana parçadan meydana gelmektedir. Bu motorlar, yüksek performansı, uzun çalışma ömrü ve düşük satın almadan dolayı modern hidrolik sistemlerde geniş bir şekilde kullanılmaktadır. Farklı iletim hacmi ve farklı dişli genişlikleri ile standart motor grubunda yer almaktadırlar. Daha fazla konfigürasyon varyantları, farklı flanş ve dişli kombinasyonları ile mümkün olacaktır.

2. KONSTRÜKSİYON

Dişli motorlar genellikle alüminyum veya döküm gövde, bir çift dişli, iki yataklama burcu, ön kapak ve arka kapaktan oluşur. Tahrik mili, ön kapaktan geçerek şaft keçesi ile sızdırmazlık sağlanmıştır. Yatak kuvvetleri, özel yatak esnekliği sayesinde temas hattı yerine yüzey teması oluşturmak için burç tarafından absorbe edilir. Motor şaftında aksel veya radyal yük oluşturmayacak esnek bağlantı elemanlarının (kaplinler) kullanılması önerilir. Debi dalgalanmaları ve gürültü seviyesi minimuma indirilmiştir. İç sızdırmazlık keçeleri üzerinde, basınca bağlı olarak kuvvetler elde edilir ve bu durum optimum verimliliği sağlar. Aksi belirtilmedikçe, keçeler, yüksek çekme mukavemetine ve sıcaklığa dayanıklı nitril kauçuk (NBR) olacaktır. Talep edilmesi durumunda, FKM keçeler kullanılabilir.

1. GENERAL INFORMATION

Blue Ascend gear motors are composed of a high-strength aluminium alloy extruded/cast body and three main components. These motors are widely used in modern hydraulic systems due to their high performance, long service life, and economical pricing. Featuring various displacement capacities and gear widths, these motors are included in the standard motor group. For more configuration variants, different flange, gear combinations are also available.

2. CONSTRUCTION

Gear motors consist of an aluminium or cast body, a pair of gears, two bushing bearings, front cover, and a rear cover. The drive shaft passes through the front cover and is sealed with a shaft seal to ensure leak-tightness. Bearing forces are absorbed by the bushing through special bearing flexibility to create surface contact instead of a contact line. It is recommended to use flexible coupling elements (couplings) that do not generate axial or radial loads on the motor shaft. Flow pulsations and noise levels are minimized. Forces are generated on the internal sealing elements depending on the pressure, ensuring optimal efficiency. Unless otherwise specified, the seals will be made of nitrile rubber (NBR), which is resistant to high tensile strength and temperature. If requested, FKM seals can be used.

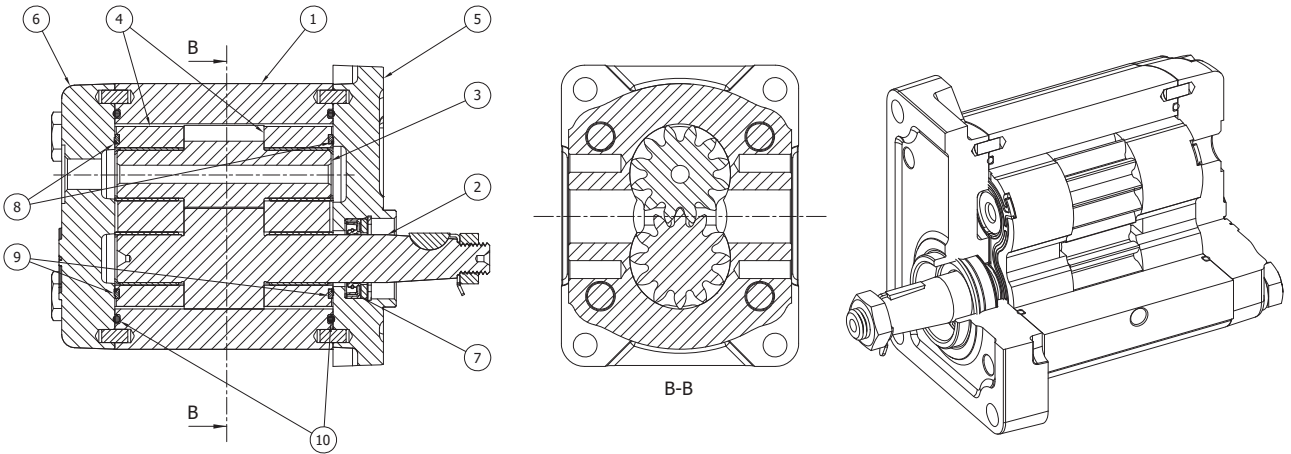

1. Gövde / Body	6. Arka Kapak / Rear Cover
2. Tahrik Eden Dişli / Drive Gear	7. Şaft Keçesi / Shaft Seal
3. Tahrik Edilen Dişli / Driven Gear	8. Takviye Keçesi / Back Up Seals
4. Burç / Bushing	9. Burç Kulak Keçesi / Bush Lobe Seals
5. Ön Kapak / Front Cover	10. Gövde Keçesi / Body Seals

3. MOTOR DÖNÜŞ YÖNÜ

Motorun ön tarafından bakıldığında ve tahrik eden dişli aşağıya gelecek şekilde motor dönüş yönü belirlenir (şekillere bakınız).

Sağ dönüşlü motorların (C) tahrik eden dişlisi sağa (saat yönünde) dönecek, giriş deliği sağda ve çıkış deliği solda olacaktır.

Sol dönüşlü motorların (A) tahrik eden dişlisi sola (saat yönünün tersine) dönecek, giriş deliği solda ve çıkış deliği sağda olacaktır.

Resimlerde görüldüğü gibi yağ, motor giriş portundan girerek dişlileri döndürür ve şaftta döner hareket (tork) üretir.

3. MOTOR DIRECTION OF ROTATIONS

The direction of rotation of a gear motor is identified by looking at the motor from the front coverside and with the drive gear turned down (see figures below).

Motors with clockwise rotation (C) have a drive gear which turns clockwise, with the inlet port on the right and the outlet port on the left.

Motors with counter-clockwise rotation (A) have a drive gear which turns counter-clockwise, with the inlet port on the left and the outlet port on the right.

As shown in the figures, the oil enters through the motor inlet port, causing the gears to rotate and generating rotational motion (torque) at the shaft.

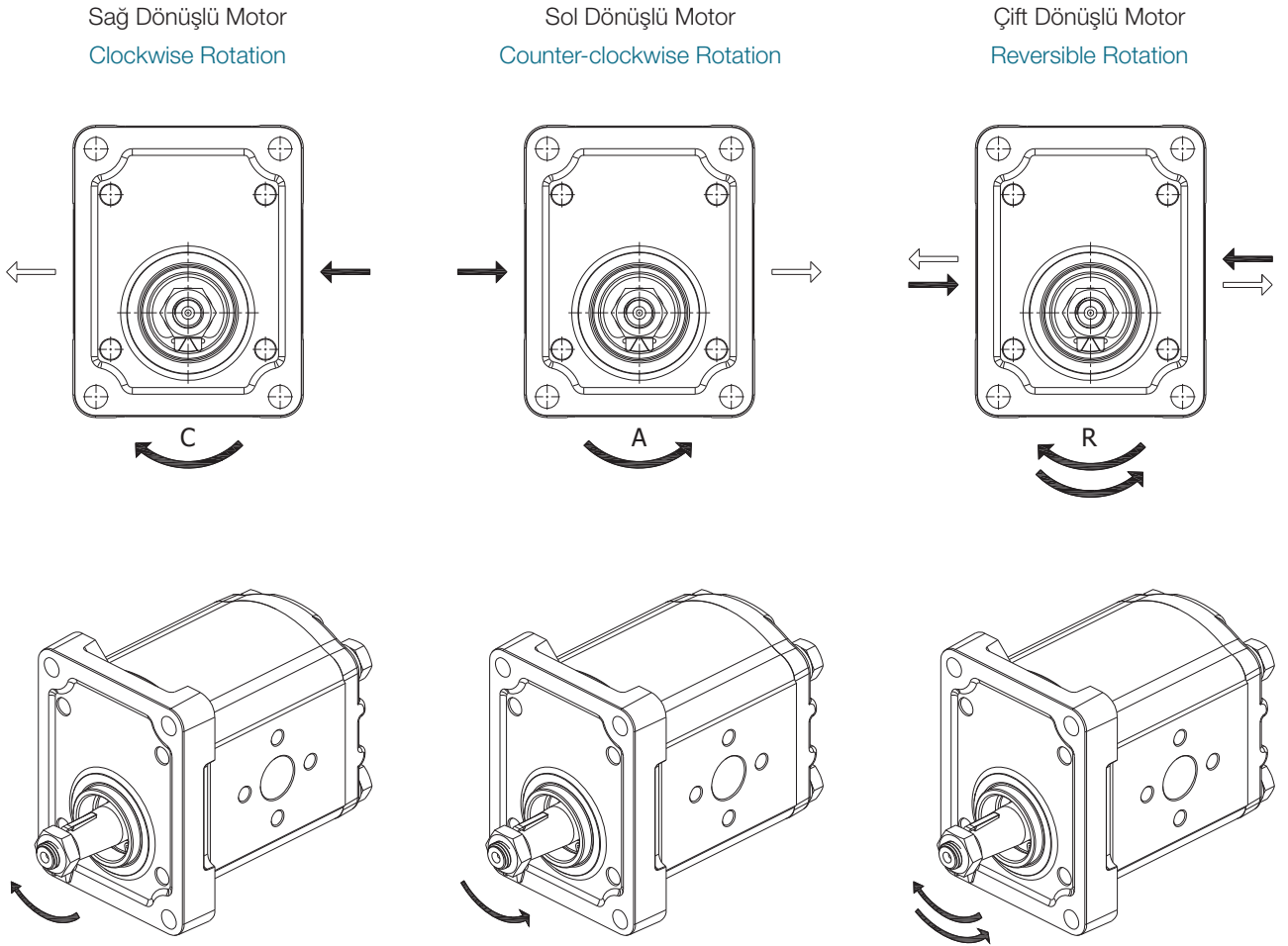

4. MOTORUN BAĞLANMASI

Motorlar, 2 veya 4 cıvata ve merkezleme çapı ile basit olarak ön kapaktan bağlanırlar. Merkezleme çapının oturacağı yuvanın, kullanıcı tarafından yapılacak kısımda 1x45° pah kırılarak ve uygun geçme toleranslarında işlenmesi, motorun yerine daha hassas bir şekilde yerleşmesini sağlar. En az titreşim için, rijit yapılan giriş çıkış bağlamaları yerine, hidrolik hortumlarla yapılacak bağlamalar tercih edilmelidir.

→ Kurulum

Sistem çalıştırılmadan önce rutin kontrollerin tamamlanması ve bazı önlemlerin alınması önerilir.

- ▶ Bağlantı flanşı, iletim hattı bağlantı elemanları ve motor üzerindeki kir ve tozları temizleyin.
- ▶ Besleme pompasının giriş ve çıkış iletim hattı uçlarının, yağ seviyesi altında ve birbirinden uzak olduğundan emin olun.
- ▶ Çalıştırmadan önce motor içerisinde yeterli seviyede hidrolik akışkan olduğundan emin olun.
- ▶ Tek yönlü motorlar için motor çalıştırma yönünün doğruluğunu kontrol edin.
- ▶ Sisteme bağlantı yapılırken motor shaftı üzerinde aksel ve radyal yüklerin oluşmadığından emin olun.
- ▶ Sistemdeki emniyet valfleri ilk çalıştırmada en düşük seviyeye ayarlanmalıdır.
- ▶ Motor için katalogta belirtilen çalışma şartları sınırları içerisinde çalışma değerlerine ulaşana kadar basıncı ve hızı kademeli olarak artırın.
- ▶ Sistem elemanlarının ve akışkan sıcaklığını sürekli olarak kontrol edin.
- ▶ Motor devreye alma ve çalıştırma sırasında sistemde hava olmadığından emin olun.
- ▶ Motor ömrünün arttırılabilmesi için ilk çalıştırmanın yükte yapılmaması önerilir.

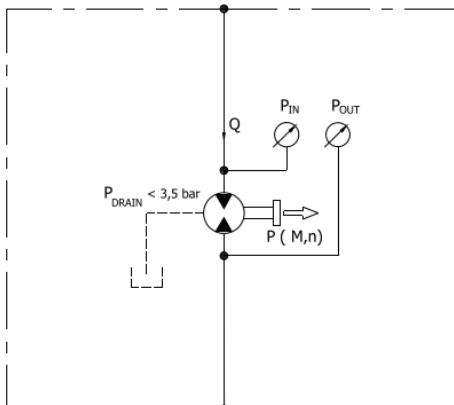

4. MOTOR MOUNTING

The motors are easily mounted from the flange with the help of 4 or 2 bolts and the spigot location. The seat for the centering diameter, which will be made by the user, should be machined with a 1x45° chamfer and smooth fit tolerances, ensuring more accurate placement of the motor. For minimal vibration, hydraulic hose connections should be preferred over rigid inlet and outlet connections.

→ Installation

Before starting the system, we suggest to complete the routine controls and adopt some simple precautions.

- ▶ Remove all dirt and dusts from flanges connecting inlet and transmission line components.
- ▶ Ensure that intake of the supply pump and return pipes are always below fluid level and as far from each other as possible.
- ▶ Ensure there is sufficient hydraulic fluid in the motor before starting.
- ▶ Check the accuracy of the motor's direction of rotation for the single rotation motors.
- ▶ Check for the motor shaft, it is necessary that the connection does not induce axial and radial loads.
- ▶ The safety valves in the system should be set to the lowest level during the initial startup.
- ▶ For the motor, gradually increase pressure and speed until the operating values are reached, within the operating conditions specified in the catalog.
- ▶ Check the temperatures of system parts and fluid continuously.
- ▶ Make sure there is no air in the system during motor startup and operating.
- ▶ It is recommended that the initial startup be performed without load to increase the motor's lifespan.

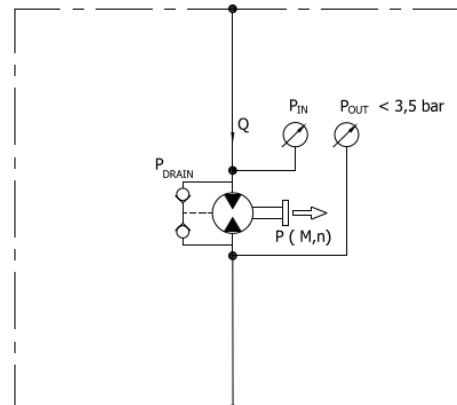

→ Yağ Tankı

- ▶ Tankta bulunan yağ miktarı dolaşımda bulunan yağ miktarının minimum 3 katı olmalıdır.
- ▶ Kullanılacak yağ, aşırı ısınmayı önleyecek ve çalışma koşullarına uygun olacak şekilde olmalıdır. Gerekli durumlarda ısı eşanjörü kullanılmalıdır.
- ▶ Tank dönüş hattındaki yağın sisteme girişini geciktirmek için giriş ve çıkış hatları arasında ayırıcı konulabilir.
- ▶ Köpüklenmenin engellenmesi için tüm dönüş hatları, minimum yağ seviyesinin altında olmalıdır.

→ Yağ İletim Hattı

- ▶ Boru ve hortum çapları minimum motor port çapları büyüklüğünde olmalıdır. Hidrolik direncin oluşmasını önlemek için dirsek, vana ve boru kesit daralmaları minimuma indirilmelidir.
- ▶ İletim hattının sızdırmaz olduğundan emin olun.
- ▶ Kayıpların azaltılması için yağ iletiminin mümkün olduğunca kısa hatlar kullanılarak yapılması önerilir.
- ▶ Esnek yapıda iletim hatlarının kullanılması titreşimi azaltacaktır.

5. MOTOR GİRİŞİ VE ÇIKIŞI (TEK YÖNLÜ)

Tek yönlü motorlar, asimetric burç ve sızdırmazlık keçesine sahiptir. Bu keçe tasarımı nedeniyle, dönüş yönü isteğe bağlı olarak değiştirilemez. Bu nedenle, çift yönlü çalışma mümkün değildir.

Düşük çıkış basıncı, yağın kaçmasını önleyen şaft keçesine basınç uygular ve keçeyi destekleyen segman da ek destek sağlar. Kaçak yağ, çıkış kısmından tahliye edilir. Maksimum çıkış basıncı, şaft keçesi tarafından sınırlanmıştır ve bu değer 3 bar geçmemelidir.

6. MOTOR GİRİŞİ VE ÇIKIŞI (ÇİFT YÖNLÜ)

Çift yönlü motorlar, her iki portun da hem giriş hem de çıkış olarak çalışmasına olanak tanıyan simetric burç ve sızdırmazlık keçesine sahiptir. Sızdırmazlık alanı, yağı tutan şaft alanına bağlıdır ve bu alanın basıncı, arka kapakta bulunan sızıntı hattı aracılığıyla sınırlanmalıdır.

→ Oil Tank

- ▶ The amount of oil in the tank must be at least 3 times the amount of oil in circulation.
- ▶ The oil to be used must be such that it prevents overheating and is suitable for operating conditions. A heat exchanger should be used when necessary.
- ▶ The intake and return lines in the tank must be spaced apart by inserting a vertical divider to delay the oil in the return line from entering the system.
- ▶ All return lines must be below the minimum oil level to prevent foaming.

→ Oil Transfer Line

- ▶ The pipe and hose diameters should be at least the size of the motor port diameter. To prevent hydraulic resistance, elbows, valves and pipe section reductions should be minimized.
- ▶ Ensure that the transfer line is leak-proof.
- ▶ To reduce the loss of power, it is recommended that the oil transfer of the lines should be short as possible.
- ▶ A length of flexible tubing is recommended to reduce the vibrations.

5. MOTOR INLET AND OUTLET (SINGLE ROTATION)

Unidirectional motors are equipped with an asymmetric bushing and shaft seal. Due to this seal design, the direction of rotation cannot be changed arbitrarily. Therefore, bidirectional operation is not possible.

The low output pressure applies force to the shaft seal, which prevents oil leakage, and the retaining ring provides additional support to the seal. Leakage oil is discharged through the outlet. The maximum output pressure is limited by the shaft seal and must not exceed 3 bar.

6. MOTOR INLET AND OUTLET (REVERSIBLE ROTATION)

Bidirectional motors feature a symmetrical bushing and sealing design, allowing both ports to operate interchangeably as inlet or outlet. The sealing area is connected to the oil-retaining shaft area, and the pressure in this area must be limited through the leakage line located in the rear cover.

Sızıntı hattında kullanılacak boru, hattaki basıncın 3 bar aşmayacak şekilde seçilmelidir. Ayrıca, ilave bir dış sızıntı bağlantı hattına ihtiyaç duyulmaması için iç sızıntılı motorlar da tercih edilebilir. Bu tür motorlarda iç sızıntı, motorun içinde yer alan çek valfler aracılığıyla sağlanmaktadır.

→ Filtreleme

Bir dişli motorun ömrü yağ içindeki yabancı maddelerin varlığına bağlıdır. Bu nedenle sistemin ömrünü uzun kılmak iyi bir filtreleme ile mümkündür. Her durumda filtreleme sistemi yağ kirliliğini aşağıdaki tabloda verilen değerlere eşit veya altında tutmasını sağlamalıdır.

Çalışma Basıncı / Working Pressure (P)	$\Delta P > 170$ bar	$\Delta P < 170$ bar
Kirlilik Sınıfı / Contamination Class (NAS 1638)	9	10
Kirlilik Sınıfı / Contamination Class (ISO 4406)	20/18/15	21/19/16
Filtre / Obtain with filter ($\beta_x=75$)	20 μm	25 μm

7. TAVSİYE EDİLEN YAĞ

Bütün hidrolik sistemlerde ISO/DIN ve SAE standartlarında belirtilen mineral esaslı hidrolik yağ kullanılması tavsiye edilir. Akışkan viskozite değer aralıkları aşağıdaki tabloda belirtilmiştir.

Önerilen Değer / Recommended Value	20/120 cSt
İzin Verilen Değer / Permitted Value	700 cSt
Başlangıçta Kabul Edilebilir Değer / Acceptable Value for Starting	<2000 cSt

8. ÇALIŞMA SICAKLIĞI

Akışkan Sıcaklık Aralığı / Fluid Temperature Range				
Sürekli / Continuous		Aralıklı / Intermittent		Keçe Tipi / Seal Type
Min. / Min.	Maks. / Max.	Min. / Min.	Maks. / Max.	
-20 °C	80 °C	-40 °C	100 °C	NBR
0 °C	100 °C	-20 °C	120 °C	FKM

The pipe used in this leakage line should be sized so that the leakage-line pressure does not exceed 3 bar. To avoid an additional external drain line, internally drained motors may be employed. In these motors, internal leakage is discharged externally through integrated check valves.

→ Filtration

A short service life of a gear motor is normally due to the presence of impurities in the oil. That is the reason an effective filter in the system to carry out regular maintenance get the system life longer. In any case, the filtering system must constantly ensure an oil contamination class equal to or less than those shown in the following table.

7. RECOMMENDED FLUIDS

We recommend using only mineral oil based hydraulic fluids that comply with the ISO/DIN or SAE standards. Recommended viscosity ranges are given in the table below.

8. OPERATION TEMPERATURE

→ Soğuk Çalıştırma

Soğuk çalıştırma sırasında (kısa süreli) aşağıdaki tabloda verilen sınır değerler uygulanabilir.

Minimum Giriş Basıncı / Minimum Inlet Pressure	0,7 bar (10 psi)
Maksimum Sızıntı Basıncı / Maximum Drain Pressure	+50% (Standart Değerler / Standard Values)
Minimum Sıcaklık / Minimum Temperature	-40 °C (-40 °F)
Maksimum Yağ Viskozitesi / Maximum Oil Viscosity	<2000 mm ² /s (cst)

Ortam sıcaklığı -20 °C' nin altında ise yağ sıcaklığı -20 °C' ye ulaşana kadar sistem hızı ve basıncı sınırlanmalıdır.

→ Cold Start

During cold start (short term) the limit values given in the table below may be applied.

If the ambient temperatures is below -20 °C, the system speed and pressure should be limited until the oil temperature reaches -20 °C.

→ Basınç Tanımlamaları

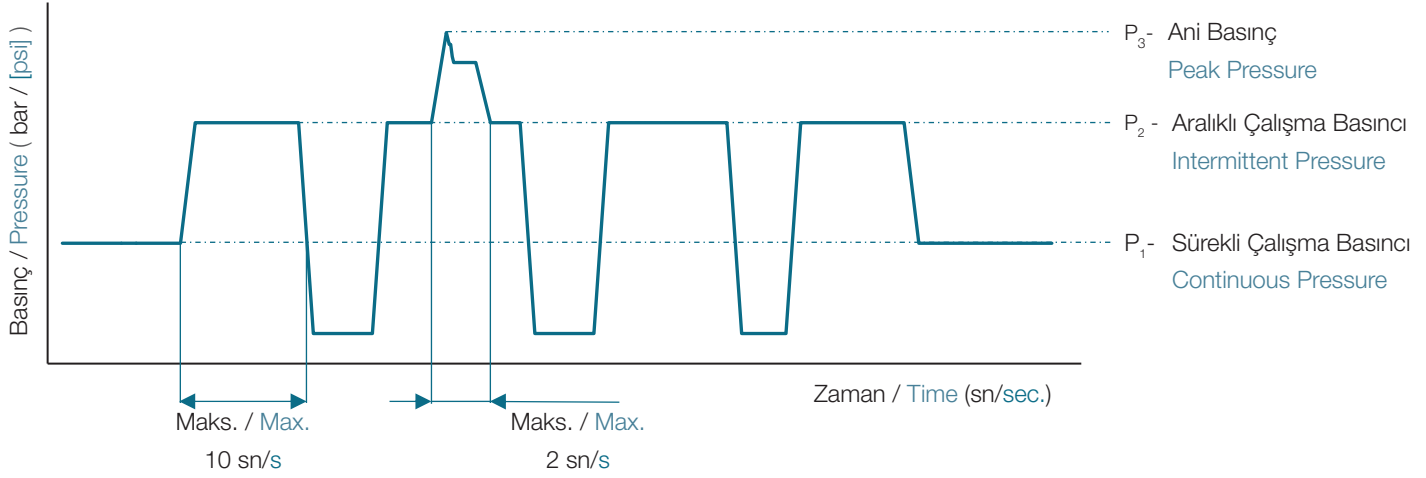

→ Keçe Özellikleri

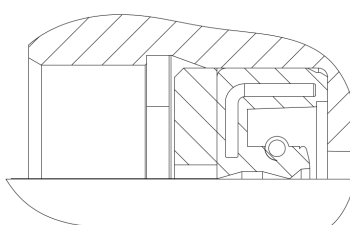
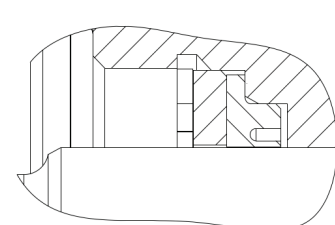
	Standart Şaft Keçesi Standard Shaft Seal	Yüksek Basıncılı Şaft Keçesi High Pressure Shaft Seal
Tek ve Çift Yönlü Motorlar - Single and Reversible Rotation Motors	Max 3 bar (44 psi)	Max 25 bar (363 psi) **
		

* Basınç değerleri şaft dönüş hızına bağlı olarak değişebilmektedir. Pressure values may vary depending on the shaft rotation speed.

→ Periyodik Bakım

Motor dış yüzeyi, özellikle şaft keçesinin bulunduğu bölge temiz tutulmalıdır. Bu bölgede bulunan toz ve kir aşındırıcı özellik göstererek keçe ömrünü düşürmektedir. Keçe aşınması sızıntıya sebep olabilir. Sistem içerisinde bulunan akışkanı temiz tutmak için filtreleri düzenli olarak değiştirin. Sistemin çalışma koşullarına göre periyodik olarak yağ seviyesi kontrol edilmeli ve yağ değişimi yapılmalıdır.

9. KAVİTASYON

Modern hidrolik sistemlerde kullanılan yağın büyük çoğunluğunda hacimsel olarak yaklaşık %10 oranında çözünmüş halde hava vardır. Sistem içinde belirli vakum şartlarında bu hava yağdan ayrışır ve hava kabarcıkları oluşturur. Bu hava cepleri belirli basınçlarda parçalanarak temasta olduğu malzemeyi aşındırarak zarar verir. Yukarıdaki açıklamalardan da anlaşılacağı üzere yağdaki hava oranı ne kadar büyükse yapacağı aşınma da o derece büyük olacaktır. Uygun olmayan boru çapları, keskin dönüşler, ani kesit değişimleri, hat üzerindeki kaçaklar ve çalışma sırasında meydana gelen ani duruşlar (giriş yağının anlık kesilmesi) kavitezyon riskini artırır. Bu riskin önlenmesi için antikavitezyon çek valfi kullanılmalıdır.

10. TAHRİK ŞEKİLLERİ

Elastik kaplinler radyal ve aksenal yük taşımazlar. Aksenal ve radyal yönde minimum 0,25 mm boşluğu olan bir kaplin seçilmelidir. Üç parçalı elastik kaplinler tavsiye edilir.

→ Periodical Maintenance

The motor exterior, especially the area where the shaft seal is located, should be kept clean. Dust and dirt in this area have an abrasive effect and reduce lifespan of the seal. Seal wear can cause leakage. Change the filters regularly to keep the fluid in the system clean. The oil level should be checked periodically and the oil should be changed according to the operating conditions of the system.

9. CAVITATION

Hydraulic oil used in the majority of systems contains about 10% dissolved air by volume. This air under certain conditions of vacuum within the systems is released from the oil and will cause air bubbles. These air pockets collapse if then subjected to pressure and this collapse creates erosion of the adjacent metal. It is obvious from the above that the greater the air content within the oil is then the more severe will be the resultant erosion created. Improper pipe diameters, sharp bends, sudden cross-sectional changes, leaks in the line, and sudden stoppages during operation (instantaneous interruption of inlet oil flow) increase the risk of cavitation. To prevent this risk, an anti-cavitation check valve should be used.

10. DRIVE ARRANGEMENTS

The flexible coupling does not transfer any radial or axial force to the motor. A coupling with a minimum clearance of 0,25 mm in the axial and radial direction should be chosen. A three pieces flexible couplings are recommended.

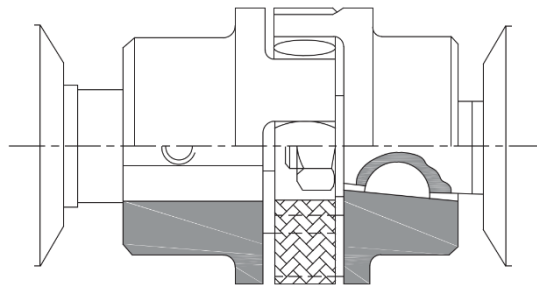

11. ÖN YATAKSIZ, KAYIŞ VE DİŞLİ İLE TAHRİK

V kayışına veya diş tahrik dişlisine motor tahriki önerildiği zaman aşağıdaki uygulama detayına bakınız.

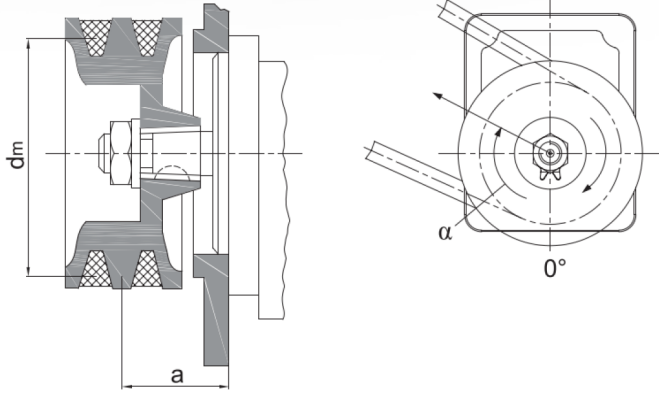

11. V-BELTS AND GEAR WHEELS WITHOUT OUTBOARD BEARING

When motor drive is recommended for the V-belt or the external drive gear, please refer to the following application detail.

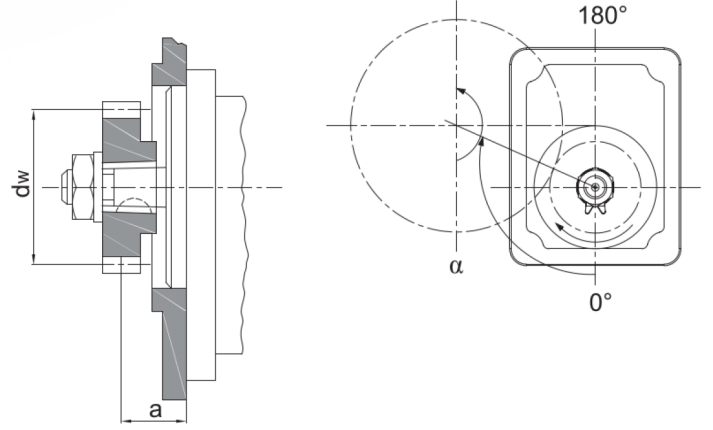

12. ÖN YATAK

V kayışını, diş tahrik dişlisini veya fanı tahrik eden motorlarda, radyal ve aksenal yük nedeniyle oluşabilecek muhtemel problemlerin önlenmesi için ön yatak kullanılmalıdır.

12. OUTBOARD BEARING

For motors driving a V-belt, external drive gear or fan, an outboard bearing must be used to prevent potential problems that may arise due to radial and axial loads.

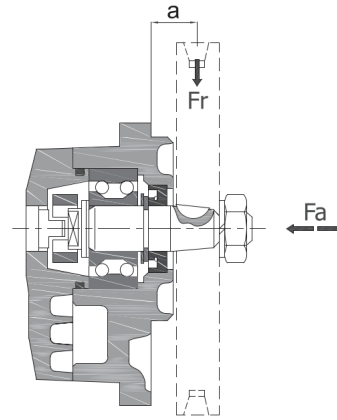

13. VALFLİ MOTORLAR

Fan sürücü ve diğer uygulama sistemlerinde motor üzerinde emniyet valfi veya oransal emniyet valfini uygulamak mümkündür. Emniyet valflerinde, motorun her devrinde debi sabit olacaktır. Fazla debi motor çıkış portuna geçmekte veya tahliye portu ile motor dışına alınabilmektedir.

13. GEAR MOTORS WITH INTEGRAL VALVES

It is possible to apply a relief valve or proportional relief valve on the fan drive motor and other application systems. On the relief valves, the flow rate will be fixed at all speed of the motors. The excess flow can be directed to the motor's outlet port or discharged externally through the drain port.

Basınç Hattı

*P

Pressure Line

R1/R2/R3

Emniyet Valfi
Relief Valve

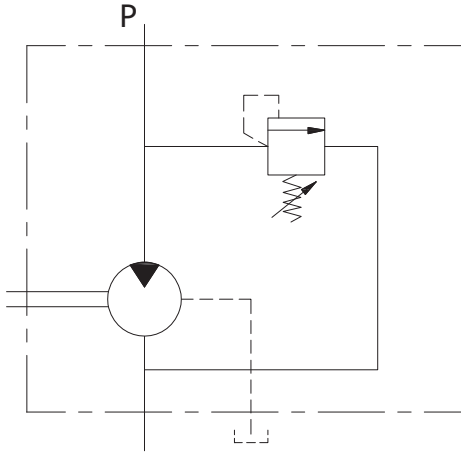

B

Oransal Basınç Emniyet Valfi
Proportional Pressure Relief Valve

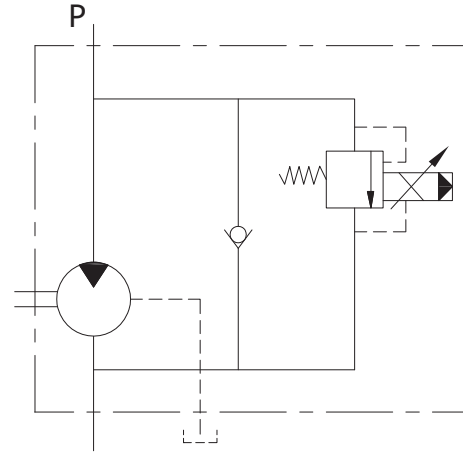

T

Çek Valf (İç Sızıntılı)
Check Valve (Internal Drain)

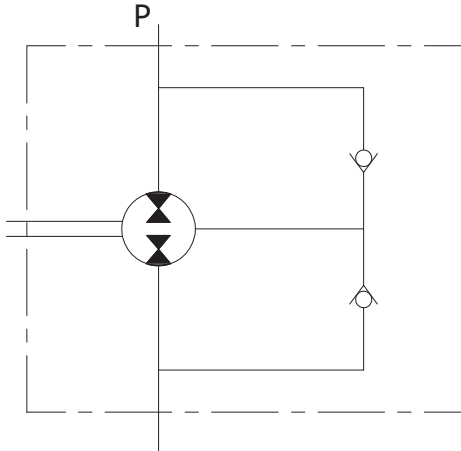

TG/TM/TU

Çek Valf (İç ve Dış Sızıntılı)
Check Valve (Internal and External Drain)

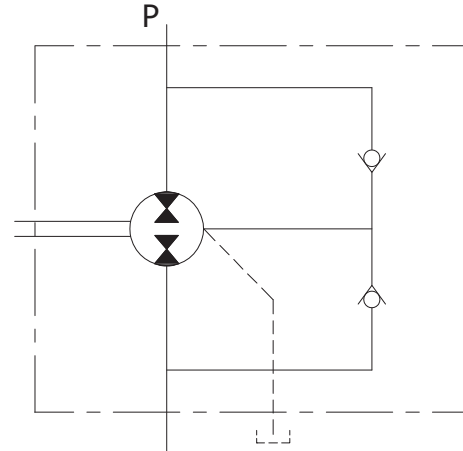

14. MOTOR HESAPLARI

Motor dizayn hesaplarında aşağıdaki parametreler esas alınır.

V (cm³/dev)	: İletim Hacmi
Q (lt/dak)	: Debi
P (bar)	: Basınç
M (Nm)	: Döndürme Torku
n (d/d)	: Hız
N (kW)	: Güç
η_v (%)	: Volumetrik Verim
η_m (%)	: Mekanik Verim
η_t (%)	: Toplam Verim

14. CALCULATION THE SPECIFICATION OF A GEAR MOTOR

The design calculation for motors are based on the following parameters.

V (cm³/rev)	: Displacement
Q (l/min)	: Flow Range
P (bar)	: Pressure
M (Nm)	: Drive Torque
n (rpm)	: Speed
N (kW)	: Power
η_v (%)	: Volumetric Efficiency
η_m (%)	: Mechanical Efficiency
η_t (%)	: Total Efficiency

FORMÜLLER / FORMULAS

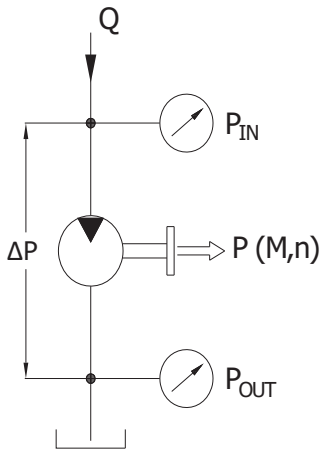

$$Q = \frac{V \cdot n}{1000 \cdot \eta_v}$$

$$N = \frac{\Delta P \cdot V \cdot n \cdot \eta_t}{600 \cdot 1000}$$

$$M = \frac{V \cdot \Delta P \cdot \eta_m}{62,83}$$

$$\eta_t = \eta_m \cdot \eta_v$$

Tavsiye Edilen Verim
Recommended Efficiency

$$\eta_v = \%95 (\approx 0,95)$$

$$\eta_m = \%85 (\approx 0,85)$$

$$\eta_t = \%81 (\approx 0,81)$$

DKM20 . 220 . R A B 02 E G 07 N

Motor Tipi / Motor Type

DKM20

Döküm Gövdeli Düz Dişli Motor
Cast Iron Body Gear Motor

İletim Hacmi / Displacement
cm³/dev / (cm³/rev)

040	3,9 cm ³ /dev (cm ³ /rev)
060	5,9 cm ³ /dev (cm ³ /rev)
080	8,0 cm ³ /dev (cm ³ /rev)
095	9,4 cm ³ /dev (cm ³ /rev)
115	11,4 cm ³ /dev (cm ³ /rev)
140	13,9 cm ³ /dev (cm ³ /rev)
160	16,0 cm ³ /dev (cm ³ /rev)
190	19,2 cm ³ /dev (cm ³ /rev)
220	21,9 cm ³ /dev (cm ³ /rev)
250	24,8 cm ³ /dev (cm ³ /rev)
280	27,9 cm ³ /dev (cm ³ /rev)

Dönüş Yönü / Rotation

A	Sol dönüş / Counter-clockwise
C	Sağ dönüş / Clockwise
R	Çift dönüş / Reversible

Ön Kapak / Front Cover

A	Dikdörtgen kapak (EUROPEAN) Square flange	Ø36,47 mm	
B	2 Civatalı - Merkezleme (GERMAN) 2 Bolts - Centering	Ø50 mm	
C	2 Civatalı - Merkezleme ve Oringli (GERMAN) 2 Bolts - Centering with Oring	Ø52 mm	
D	2 Civatalı SAE "A" (SAE "A" 2 BOLTS) 2 Bolts SAE "A"	Ø82,55 mm	
E	2 Civatalı - Merkezleme (GERMAN) 2 Bolts - Centering	Ø50 mm	
G	Dikdörtgen kapak (GERMAN) Square flange	Ø80 mm	
H	Ön yataklı (GERMAN) Outboard bearing	Ø80 mm	

Sızıntı Hattı / Drain Port

G	G 1/4"
U	7/16"-20 UNF
M	M12x1,5











Ön Yatak
Outboard Bearing

07	Var / Available
	Yok / Absent

Keçe / Seal

N	NBR
V	FKM

Tahrik Şaftı / Drive Shaft

A	Konik - Kamalı Tapered key shaft	1:5		B E G
B	Konik - Kamalı Tapered key shaft	1:8		A
C	SAE spline şaft 9 diş SAE spline shaft 9T			B D
E	Kesik şaftlı Tang drive shaft			C
F	SAE spline şaft 11 diş SAE spline shaft 11T			D
G	Spline şaft DIN 5482 Spline shaft (B17x14)			A B E G
H	Paralel şaft Parallel shaft	Ø15,875		B D G A
K	Konik - Kamalı Tapered key shaft	1:5		H
L	Konik - Kamalı Tapered key shaft	1:5		G
M	SAE spline şaft J498 10 diş SAE spline shaft 16/32 DP 10T			D

Arka Kapak / Rear Cover

S	Standart (Sızıntı Hatsız, Tek Yönlü) Standard (Without Drain Line, Single Rotation)
E	Arkadan Dış Sızıntı Hattı External Drain Rear Port
R1	Emniyet Valfi (10 - 105 Bar) Relief Valve
R2	Emniyet Valfi (70 - 210 Bar) Relief Valve
R3	Emniyet Valfi (140 - 350 Bar) Relief Valve
B	Oransal Basınç Emniyet Valfi Proportional Pressure Relief Valve
T	Çek Valf Check Valve
P	Arkadan Giriş-Çıkış Rear Inlet-Outlet

Giriş - Çıkış Delikleri
Inlet and Outlet Ports

01	Kare tip Rectangular	
02	Baklava tip Diamond	
03	Metrik diş Metric thread	
04	UNF diş UNF thread	
05	Boru diş Pipe thread	
06	SAE Dikdörtgen flanş metrik diş SAE Square flange metric thread	

-Kodlama Örneği
-Code Example

DKM20.220.CAB02SN

-Kodlama Örneği
-Code Example

DKM20.220.RAB02EGN

Motor Tipi Motor Type	İletim Hacmi Displacement cm ³ /dev (cm ³ /rev)	Maks. Basınç / Max. Pressure			Maks. Hız Max. Speed	Min. Hız Min. Speed
		P1	P2	P3		
		bar			d/d (rpm)	
DKM20.040	3,9	280	300	320	3500	650
DKM20.060	5,9	280	300	320	3500	650
DKM20.080	8,0	280	300	320	3500	650
DKM20.095	9,4	280	300	320	3500	600
DKM20.115	11,4	280	300	320	3000	600
DKM20.140	13,9	280	300	320	3000	600
DKM20.160	16,0	280	300	320	3000	600
DKM20.190	19,2	280	300	320	3000	600
DKM20.220	21,9	240	260	280	2500	600
DKM20.250	24,8	220	240	260	2500	600
DKM20.280	27,9	200	220	240	2200	600

P1	Sürekli Çalışma Basıncı
	Continuous Pressure

P2	Aralıklı Çalışma Basıncı
	Intermittent Pressure

P3	Ani Basınç
	Peak Pressure

DKM20 MOTORLARIN DEBİ EĞRİLERİ / FLOW CURVES OF DKM20 MOTORS

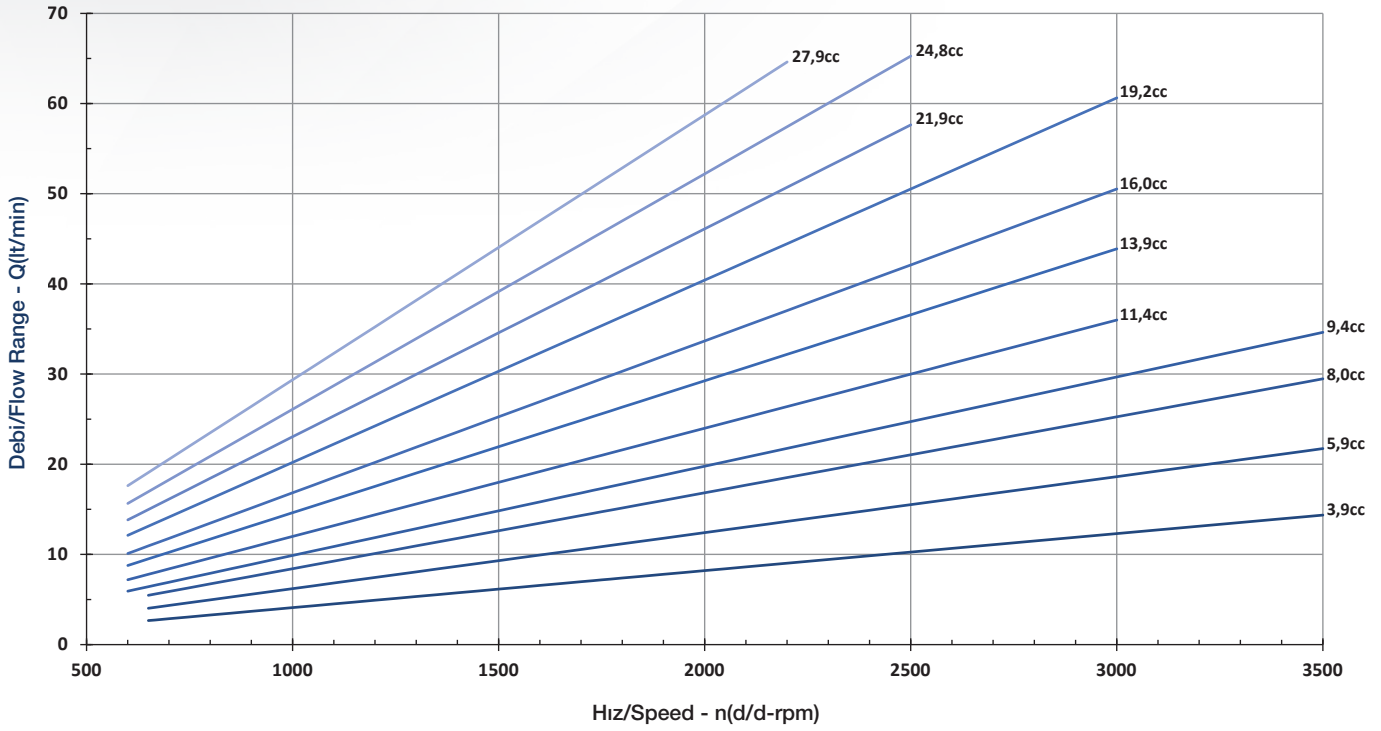

DKM20.040

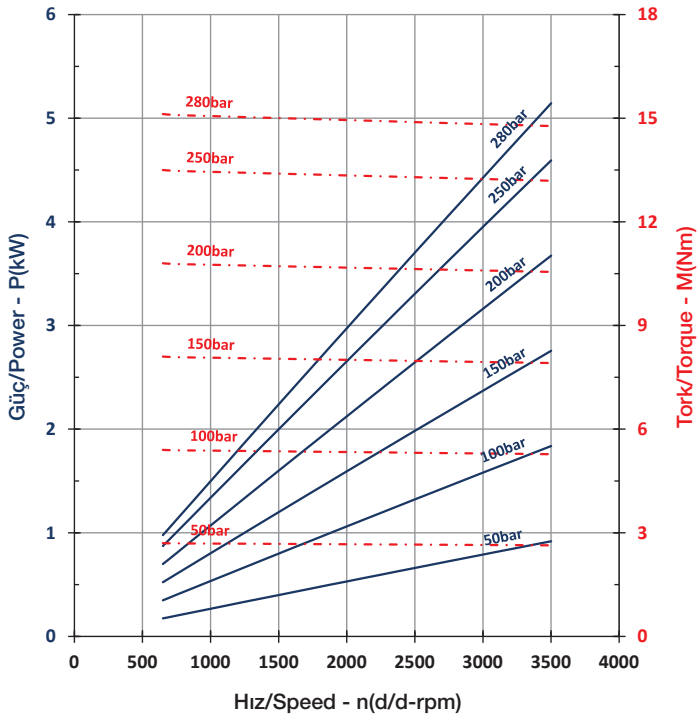

DKM20.060

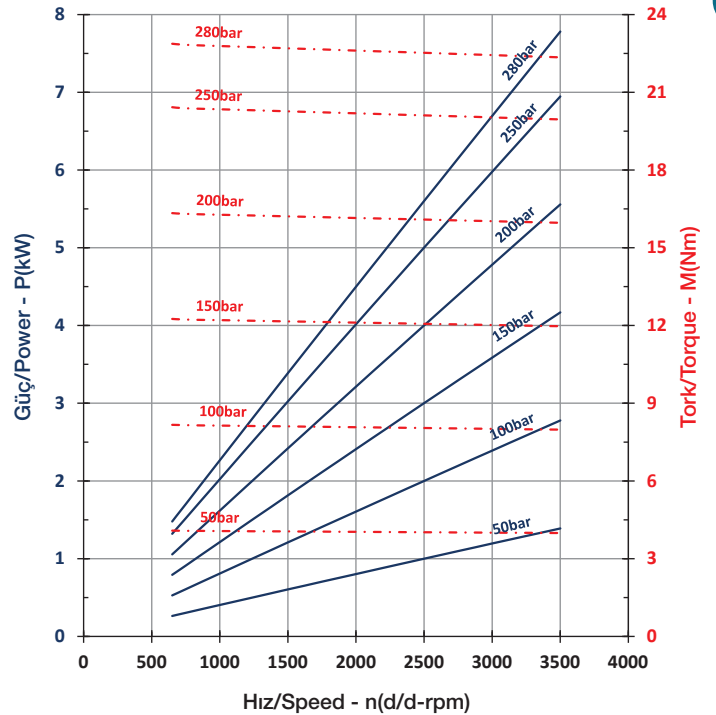

DKM20.080

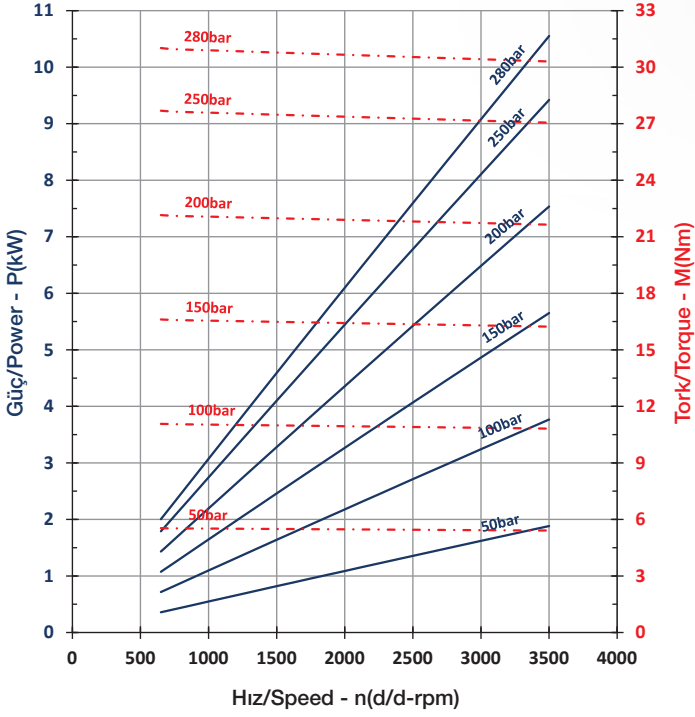

DKM20.095

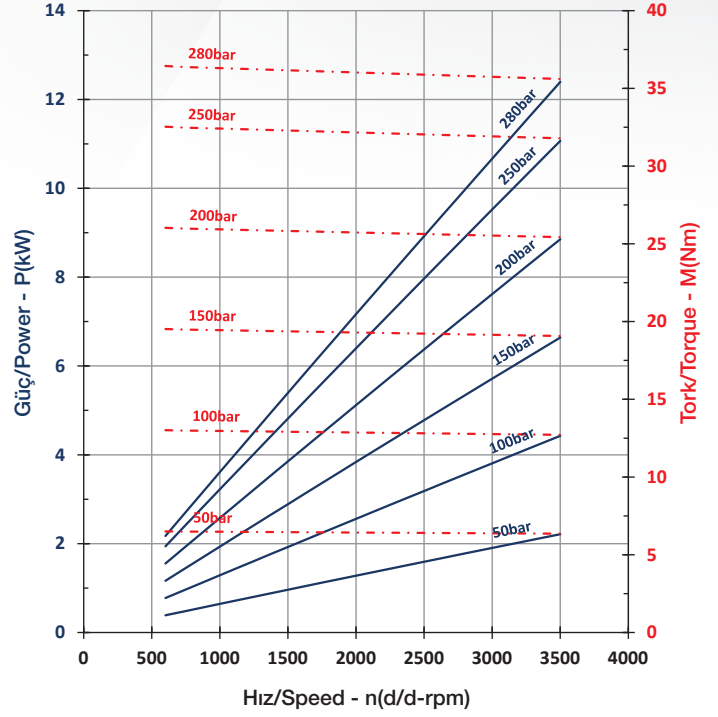

DKM20.115

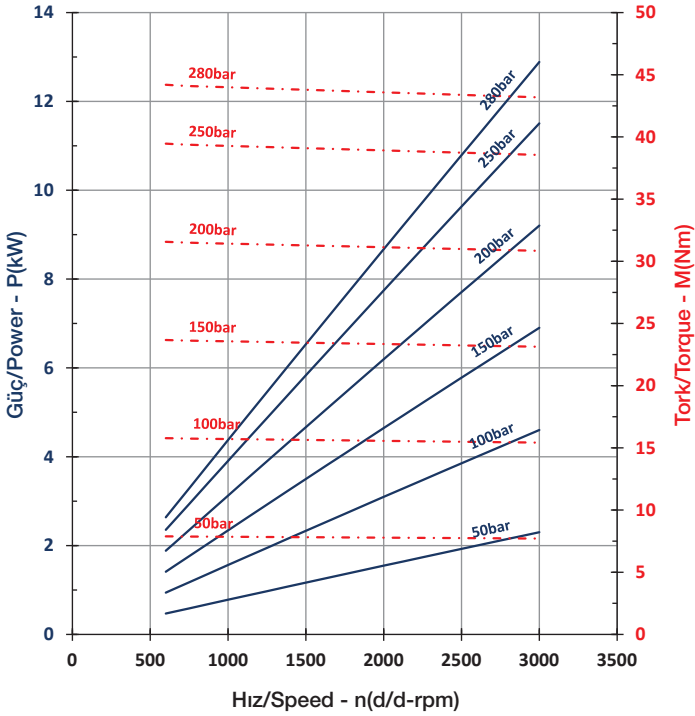

DKM20.140

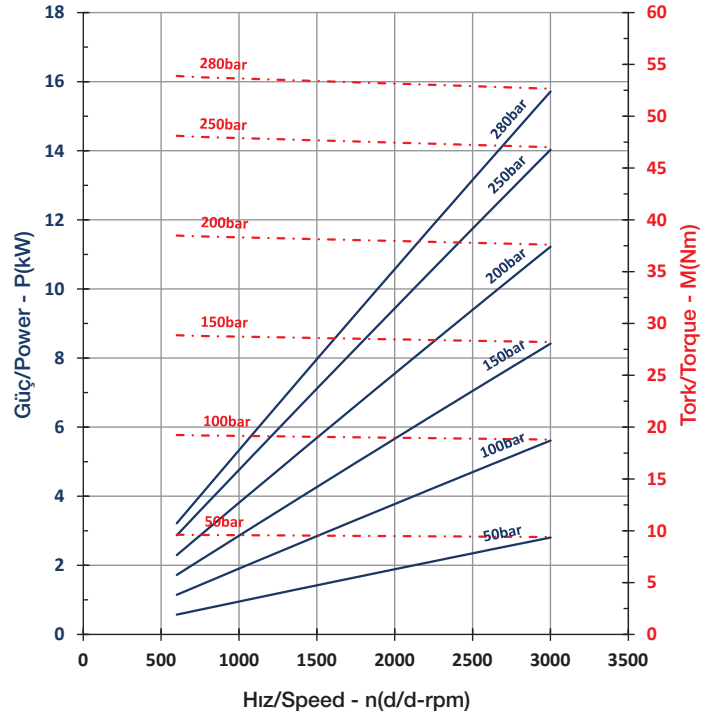

DKM20.160

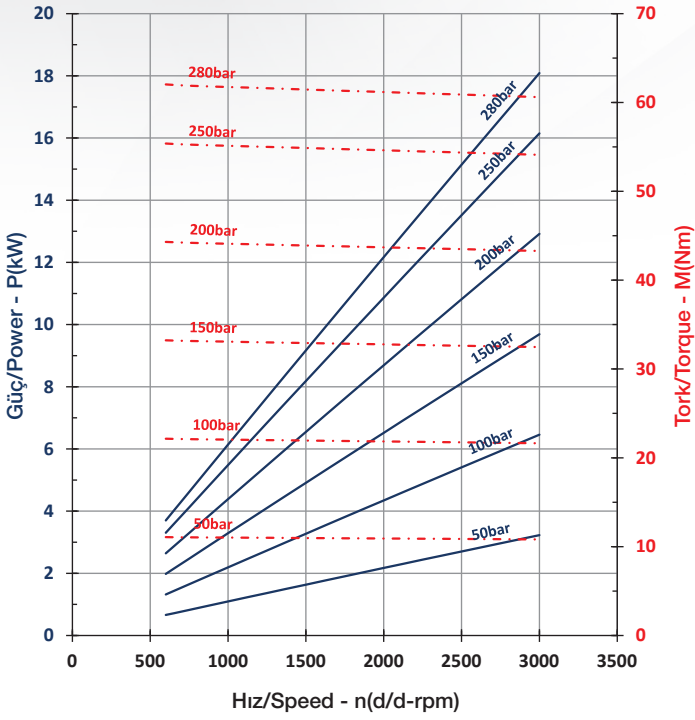

DKM20.190

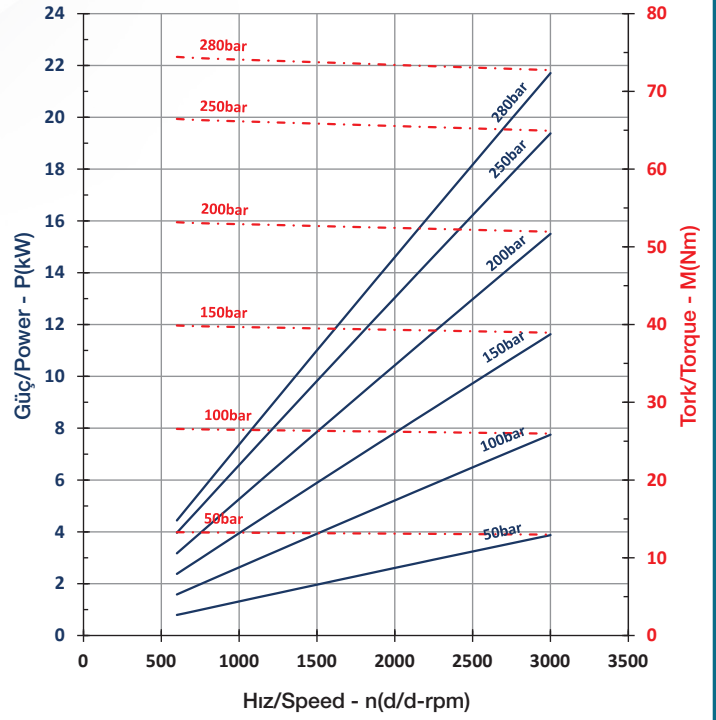

DKM20.220

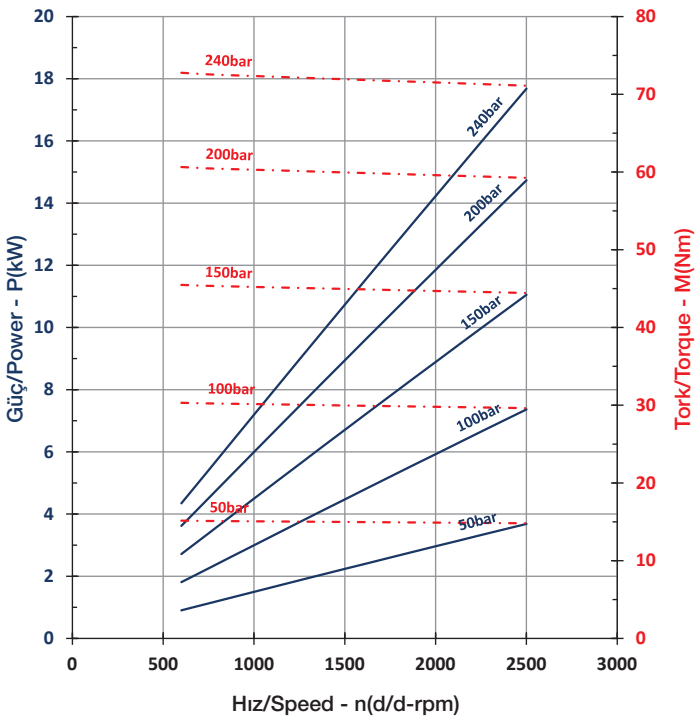

DKM20.250

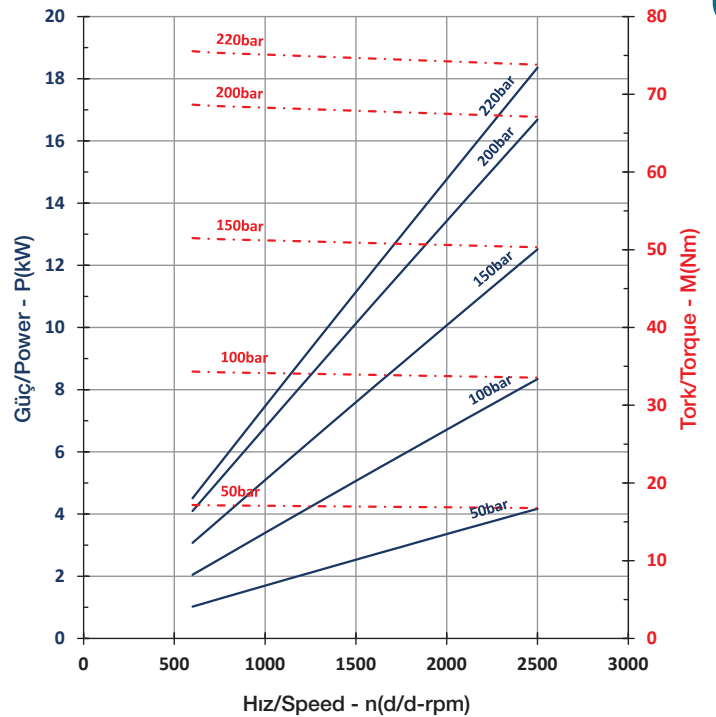

DKM20.280

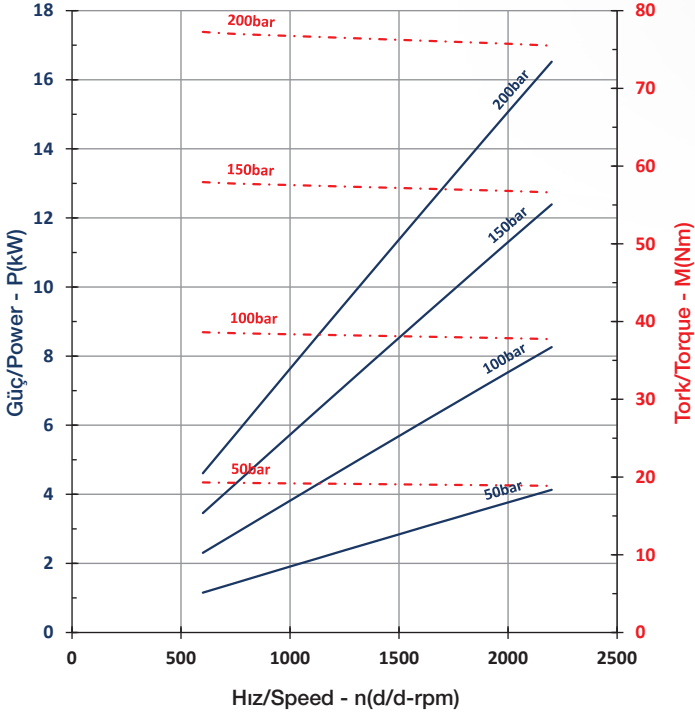

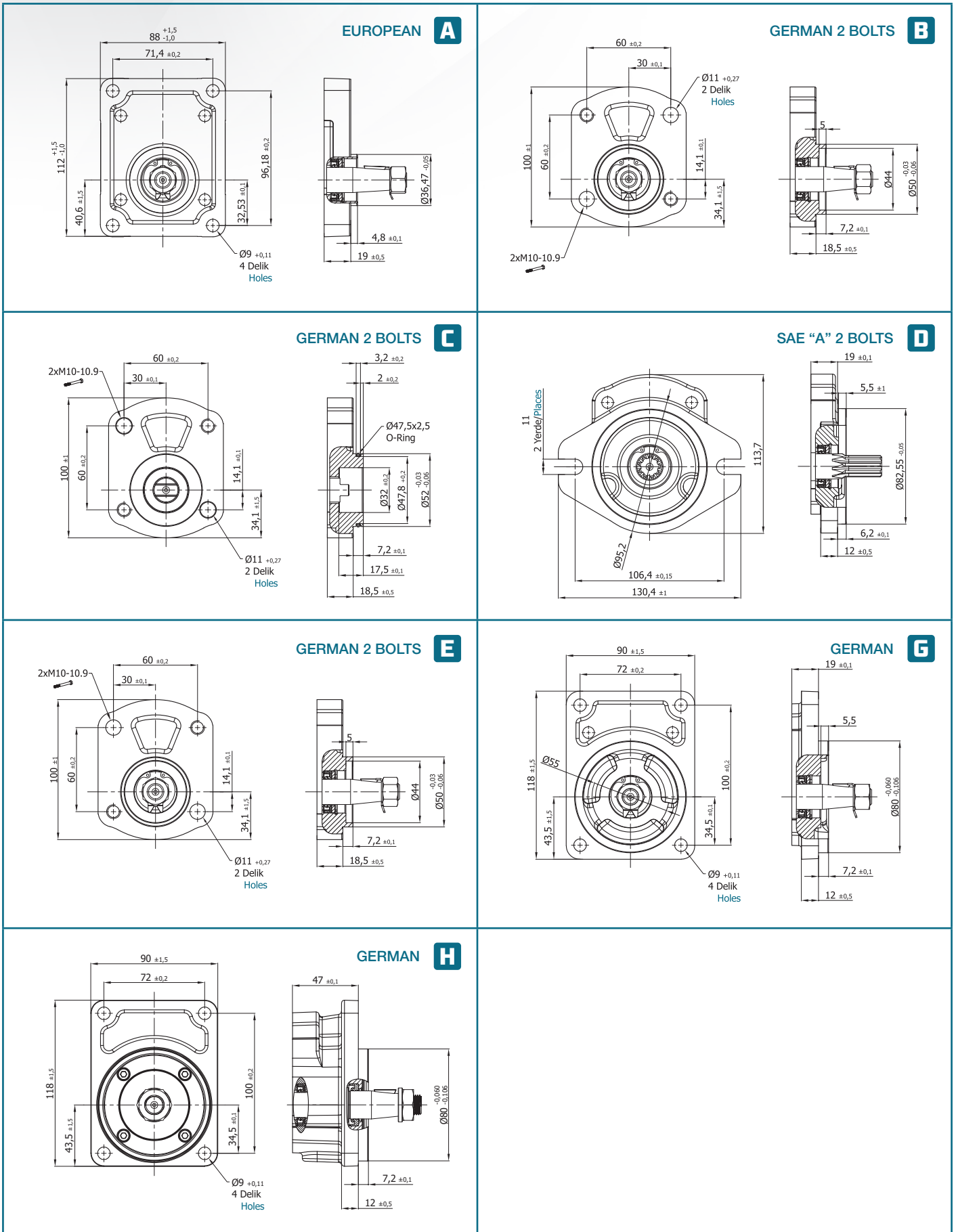

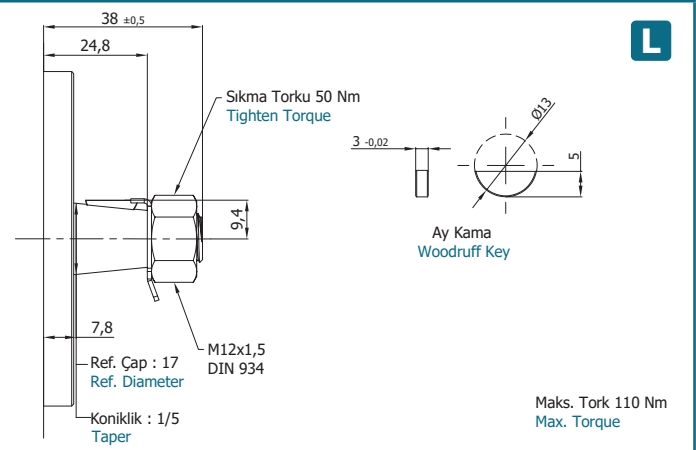
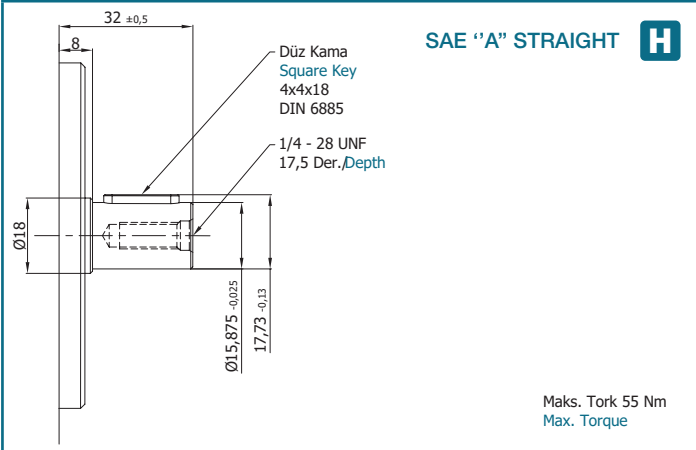
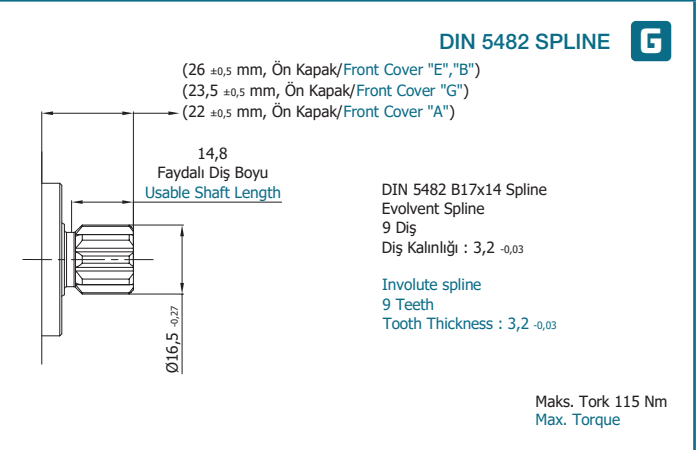
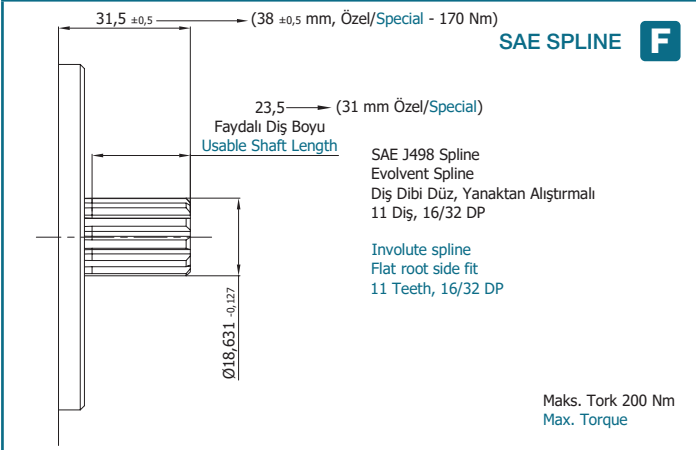
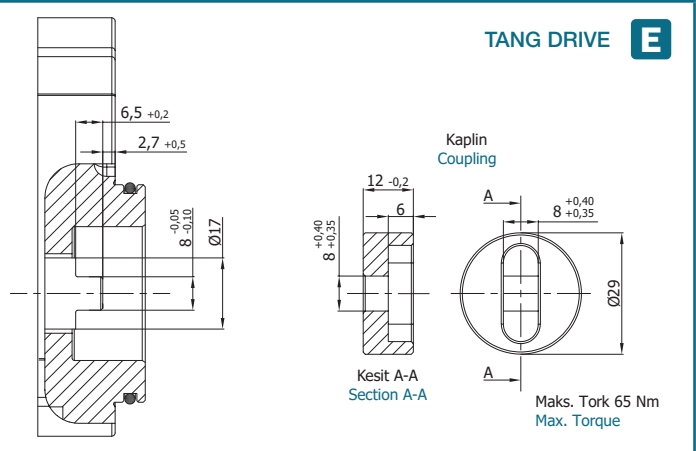
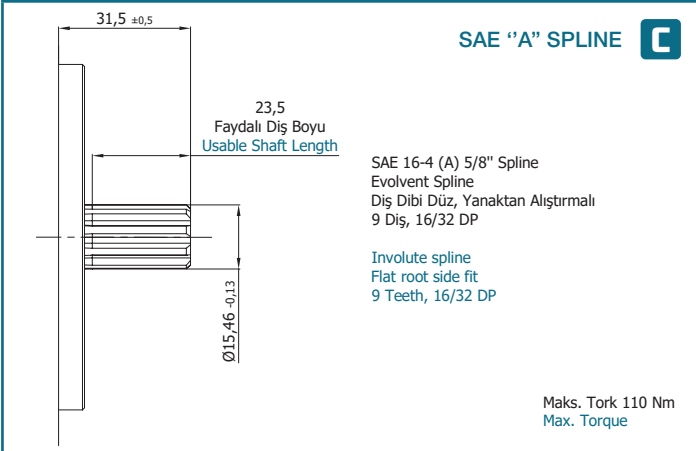
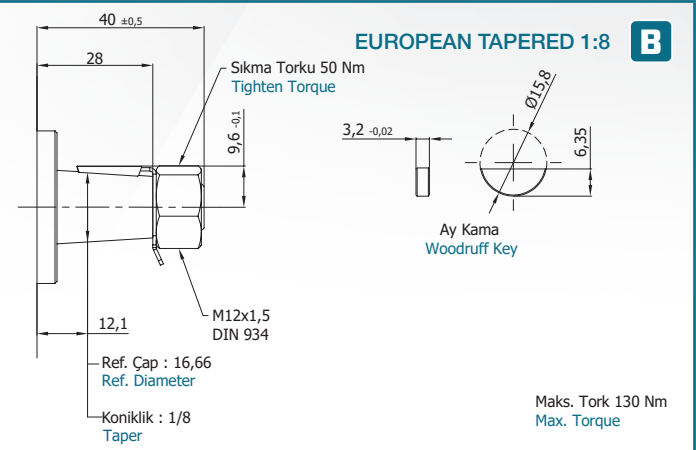
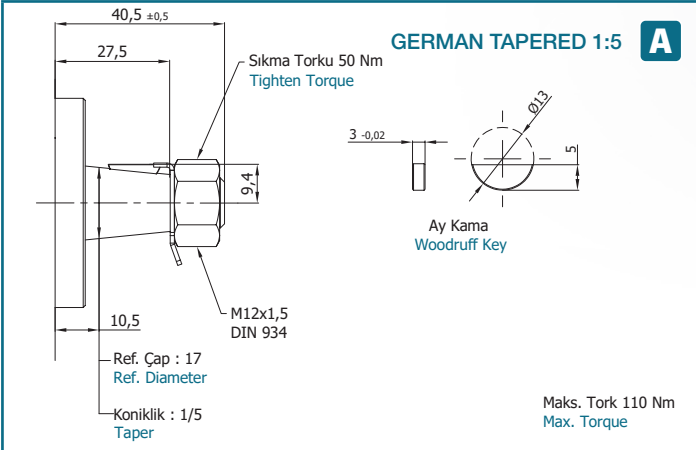

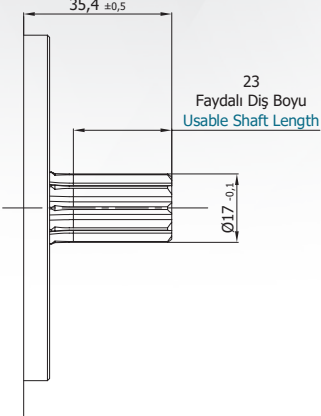
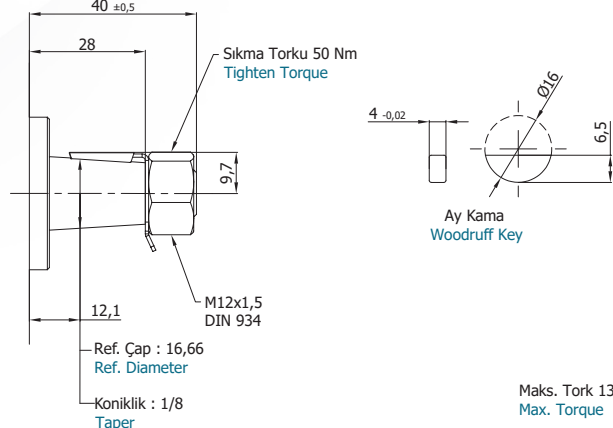
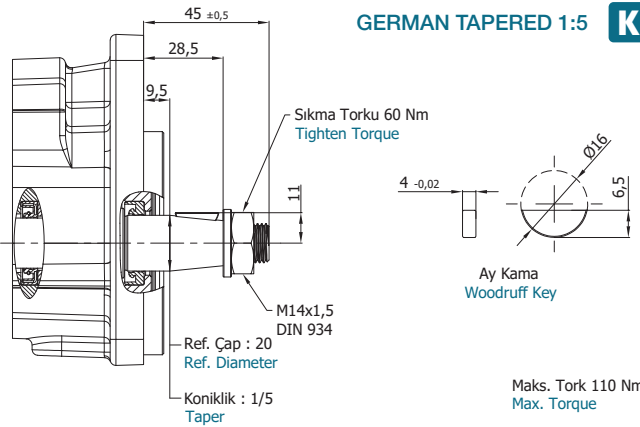
 <p>SPLINE M</p> <p>23 Faydalı Diş Boyu Usable Shaft Length</p> <p>SAE J498 A Spline Evolvent Spline Diş Dibi Düz, Yanaktan Alıstırmalı 10 Diş, 16/32 DP</p> <p>Involute spline Flat root side fit 10 Teeth, 16/32 DP</p> <p>Maks. Tork 150 Nm Max. Torque</p>	 <p>R</p> <p>Sıkma Torku 50 Nm Tighten Torque</p> <p>M12x1,5 DIN 934</p> <p>Ref. Çap : 16,66 Ref. Diameter</p> <p>Koniklik : 1/8 Taper</p> <p>Ay Kama Woodruff Key</p> <p>Maks. Tork 130 Nm Max. Torque</p>
 <p>GERMAN TAPERED 1:5 K</p> <p>Sıkma Torku 60 Nm Tighten Torque</p> <p>M14x1,5 DIN 934</p> <p>Ref. Çap : 20 Ref. Diameter</p> <p>Koniklik : 1/5 Taper</p> <p>Ay Kama Woodruff Key</p> <p>Maks. Tork 110 Nm Max. Torque</p>	

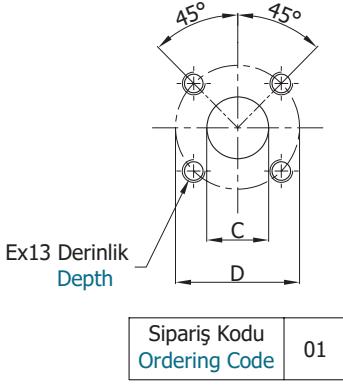
01 Kare Tipi Flaş / Rectangular Flange
German Flanged Ports - 4 Bolts

Tek Dönüş Single Rotation		İletim Hacmi Displacement cm ³ /dev (rev)	Basınç/Giriş Tarafı Pressure/Inlet Side			Çıkış Tarafı Outlet Side		
			C	D	E	c	d	e
		4	12	35	M6	12	40	M6
		6	13,5			13,5		
		8 - 25	15			20		
		28	20	40				
Çift Dönüş Reversible Rotation		İletim Hacmi Displacement cm ³ /dev (rev)	Giriş Tarafı Inlet Side			Çıkış Tarafı Outlet Side		
		4 - 16	15	35	M6	15	35	M6
		19 - 28	20	40		20	40	

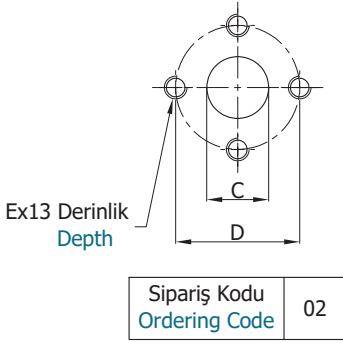
02 Baklava Tipi Flaş / Diamond Flange
European Flanged Ports - 4 Bolts

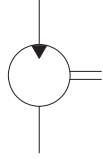
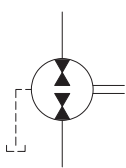
Tek Dönüş Single Rotation		İletim Hacmi Displacement cm ³ /dev (rev)	Basınç/Giriş Tarafı Pressure/Inlet Side			Çıkış Tarafı Outlet Side		
			C	D	E	c	d	e
		4	12	30,2	M6	12	30,2	M6
		6 - 8	13,5			13,5		
		9,5 - 25				20		
		28	20	40		M8	20	
Çift Dönüş Reversible Rotation		İletim Hacmi Displacement cm ³ /dev (rev)	Giriş Tarafı Inlet Side			Çıkış Tarafı Outlet Side		
		4 - 16	13,5	30,2	M6	13,5	30,2	M6
		19 - 28	20	40		M8	20	

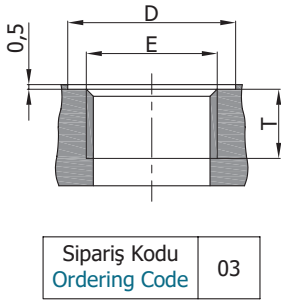
03 Metrik Diş
Metric Thread

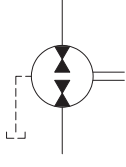
Tek Dönüş Single Rotation		İletim Hacmi Displacement cm ³ /dev (rev)	Basınç/Giriş Tarafı Pressure/Inlet Side			Çıkış Tarafı Outlet Side		
			T	D	E	t	d	e
		4 - 6	16	30	M18x1,5	16	30	M18x1,5
		8 - 16	19	35	M22x1,5	19	40	M27x2
		19 - 28				22	45	M33x2
Çift Dönüş Reversible Rotation		İletim Hacmi Displacement cm ³ /dev (rev)	Giriş Tarafı Inlet Side			Çıkış Tarafı Outlet Side		
		4 - 16	19	35	M22x1,5	19	35	M22x1,5
		19 - 28		40			M27x2	

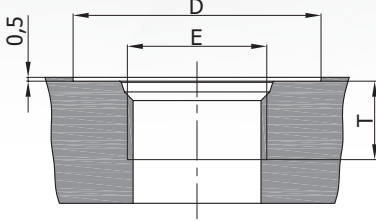
04 Diş / Thread
 SAE Straight Thread O-Ring Port J1926-1

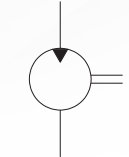
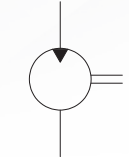
 Sipariş Kodu
 Ordering Code **04**

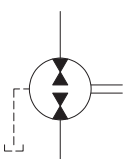
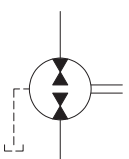
Tek Dönüş Single Rotation		İletim Hacmi Displacement cm ³ /dev (rev)	Basınç/Giriş Tarafı Pressure/Inlet Side			Çıkış Tarafı Outlet Side								
			T	D	E	t	d	e						
4 - 6		13	25	9/16"-18 UNF-2B	13	25	9/16"-18 UNF-2B							
								8	16	35	7/8"-14 UNF-2B	16	35	7/8"-14 UNF-2B

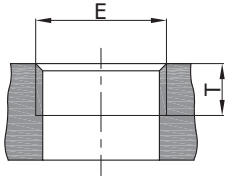
Çift Dönüş Reversible Rotation		İletim Hacmi Displacement cm ³ /dev (rev)	Giriş Tarafı Inlet Side			Çıkış Tarafı Outlet Side		
			T	D	E	T	D	E
4 - 16		16	35	7/8"-14 UNF-2B	16	35	7/8"-14 UNF-2B	
								19 - 28

05 Boru Diş / Pipe Thread
 Gas Straight Thread Ports British standard pipe parallel (55°) conforms to UNI-ISO 228

 Sipariş Kodu
 Ordering Code **05**

Tek Dönüş Single Rotation		İletim Hacmi Displacement cm ³ /dev (rev)	Basınç/Giriş Tarafı Pressure/Inlet Side		Çıkış Tarafı Outlet Side	
			T	E	t	e
4 - 16		16	16	G 1/2	16	G 3/4

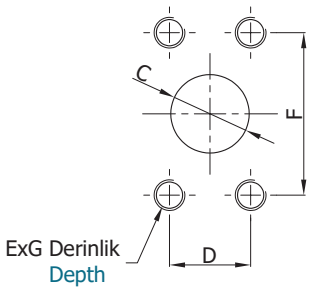
Çift Dönüş Reversible Rotation		İletim Hacmi Displacement cm ³ /dev (rev)	Giriş Tarafı Inlet Side		Çıkış Tarafı Outlet Side	
			T	E	T	E
4 - 16		16	16	G 1/2	16	G 1/2

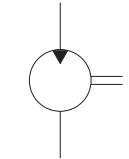
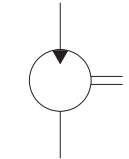
06 SAE Dikdörtgen Flaş Metrik Diş / SAE Flanged Ports J518 - Standard Pressure Series 3000 PSI
 SAE Square Flange Metric Thread / Metric thread ISO 60° conforms to ISO / R 262

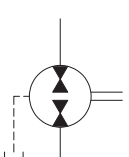
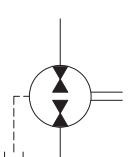
 Sipariş Kodu
 Ordering Code **06**

Tek Dönüş Single Rotation		İletim Hacmi Displacement cm ³ /dev (rev)	Basınç/Giriş Tarafı Pressure/Inlet Side				Çıkış Tarafı Outlet Side									
			C	D	ExG	F	c	d	exg	f						
4 - 11,5		12	17,5	M8x13	38,1	12	17,5	M8x13	38,1							
										14 - 19	38,1	17,5	19	47,6	M10x14	22,2

Çift Dönüş Reversible Rotation		İletim Hacmi Displacement cm ³ /dev (rev)	Giriş Tarafı Inlet Side				Çıkış Tarafı Outlet Side										
			C	D	ExG	F	C	D	ExG	F							
4 - 11,5		12	17,5	M8x13	38,1	12	17,5	M8x13	38,1								
										14 - 22	19	47,6	22,2	19	47,6	M10x14	22,2

A Ön Kapak
Front Cover

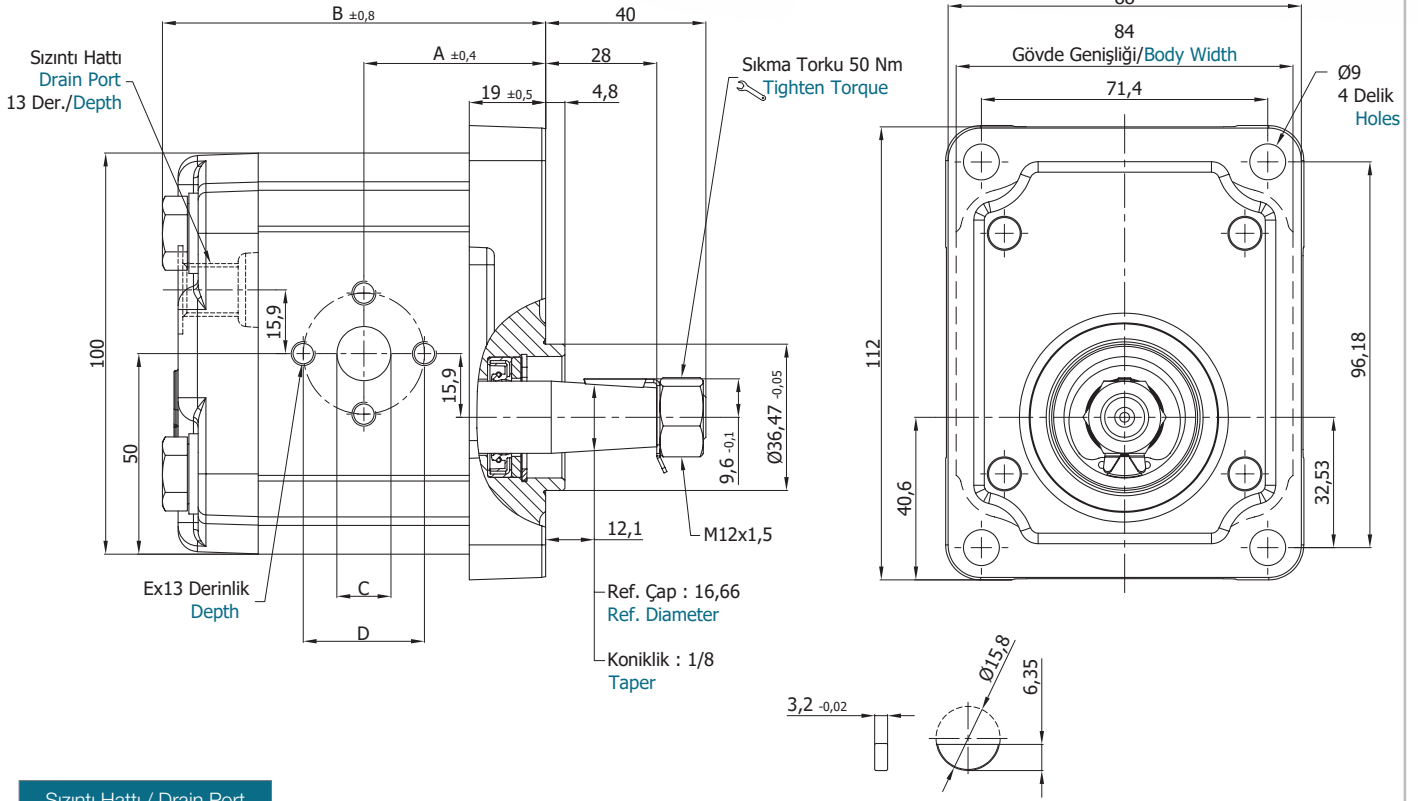
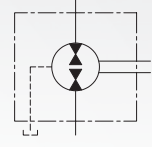
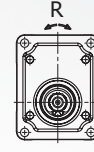
B Şaft Tipi
Shaft Type



Sızıntı Hattı / Drain Port

G	G 1/4"
U	7/16"-20 UNF
M	M12x1,5

Motor Kodu Motor Code	İletim Hacmi Displacement cm ³ /dev (cm ³ /rev)	Maks. Basınç Max. Pressure (bar)	Maks. Hız Max. Speed d/d (rpm)	A ±0,4	B ±0,8	Giriş - Inlet			Çıkış - Outlet		
						C	D	E	C	D	E
DKM20.040.RAB02EGN	3,9	280	3500	42,2	89,2	13,5	30,2	M6	13,5	30,2	M6
DKM20.060.RAB02EGN	5,9			43,8	92,3						
DKM20.080.RAB02EGN	8,0			45,3	95,4						
DKM20.095.RAB02EGN	9,4			46,5	97,7						
DKM20.115.RAB02EGN	11,4		3000	48,0	100,9						
DKM20.140.RAB02EGN	13,9			50,0	104,8						
DKM20.160.RAB02EGN	16,0			51,5	107,9						
DKM20.190.RAB02EGN	19,2			60,0	125,0						
DKM20.220.RAB02EGN	21,9	240	2500	62,3	129,3	20	40	M8	20	40	M8
DKM20.250.RAB02EGN	24,8	220		64,8	134,4						
DKM20.280.RAB02EGN	27,9	200		67,0	138,7						

A Ön Kapak
Front Cover

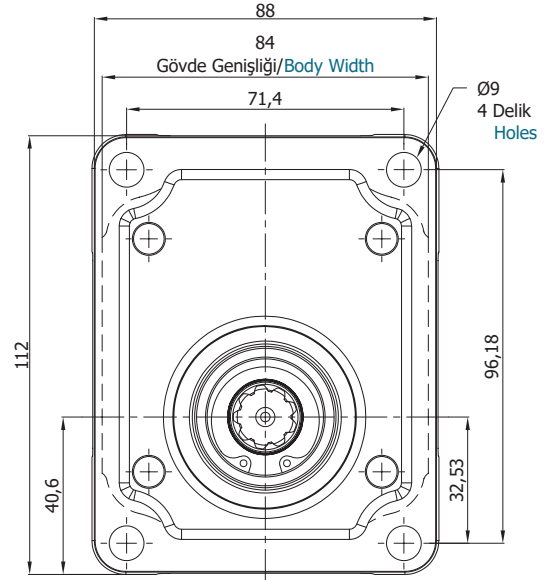
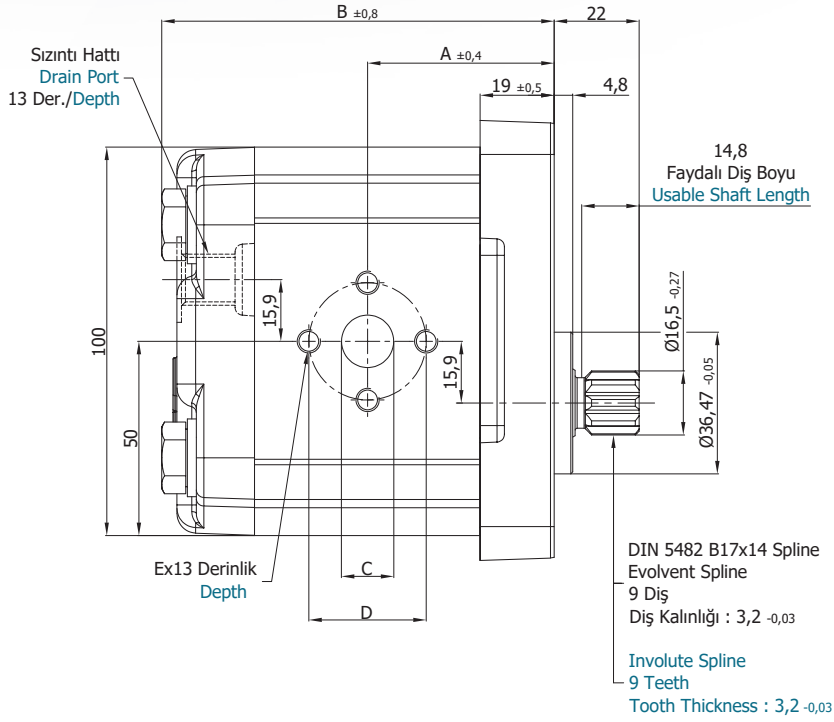
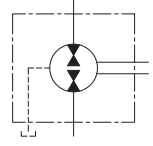
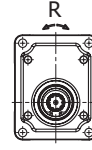
G Şaft Tipi
Shaft Type

Sızıntı Hattı / Drain Port

G	G 1/4"
U	7/16"-20 UNF
M	M12x1,5

Motor Kodu Motor Code	İletim Hacmi Displacement cm ³ /dev (cm ³ /rev)	Maks. Basınç Max. Pressure (bar)	Maks. Hız Max. Speed d/d (rpm)	A ±0,4	B ±0,8	Giriş - Inlet			Çıkış - Outlet		
						C	D	E	C	D	E
DKM20.040.RAG02EGN	3,9	280	3500	42,2	89,2	13,5	30,2	M6	13,5	30,2	M6
DKM20.060.RAG02EGN	5,9			43,8	92,3						
DKM20.080.RAG02EGN	8,0			45,3	95,4						
DKM20.095.RAG02EGN	9,4			46,5	97,7						
DKM20.115.RAG02EGN	11,4		3000	48,0	100,9	20	40	M8	20	40	M8
DKM20.140.RAG02EGN	13,9			50,0	104,8						
DKM20.160.RAG02EGN	16,0			51,5	107,9						
DKM20.190.RAG02EGN	19,2			60,0	125,0						
DKM20.220.RAG02EGN	21,9	240	2500	62,3	129,3	20	40	M8	20	40	M8
DKM20.250.RAG02EGN	24,8	220		64,8	134,4						
DKM20.280.RAG02EGN	27,9	200		2200	67,0						

B Ön Kapak
Front Cover

A Şaft Tipi
Shaft Type

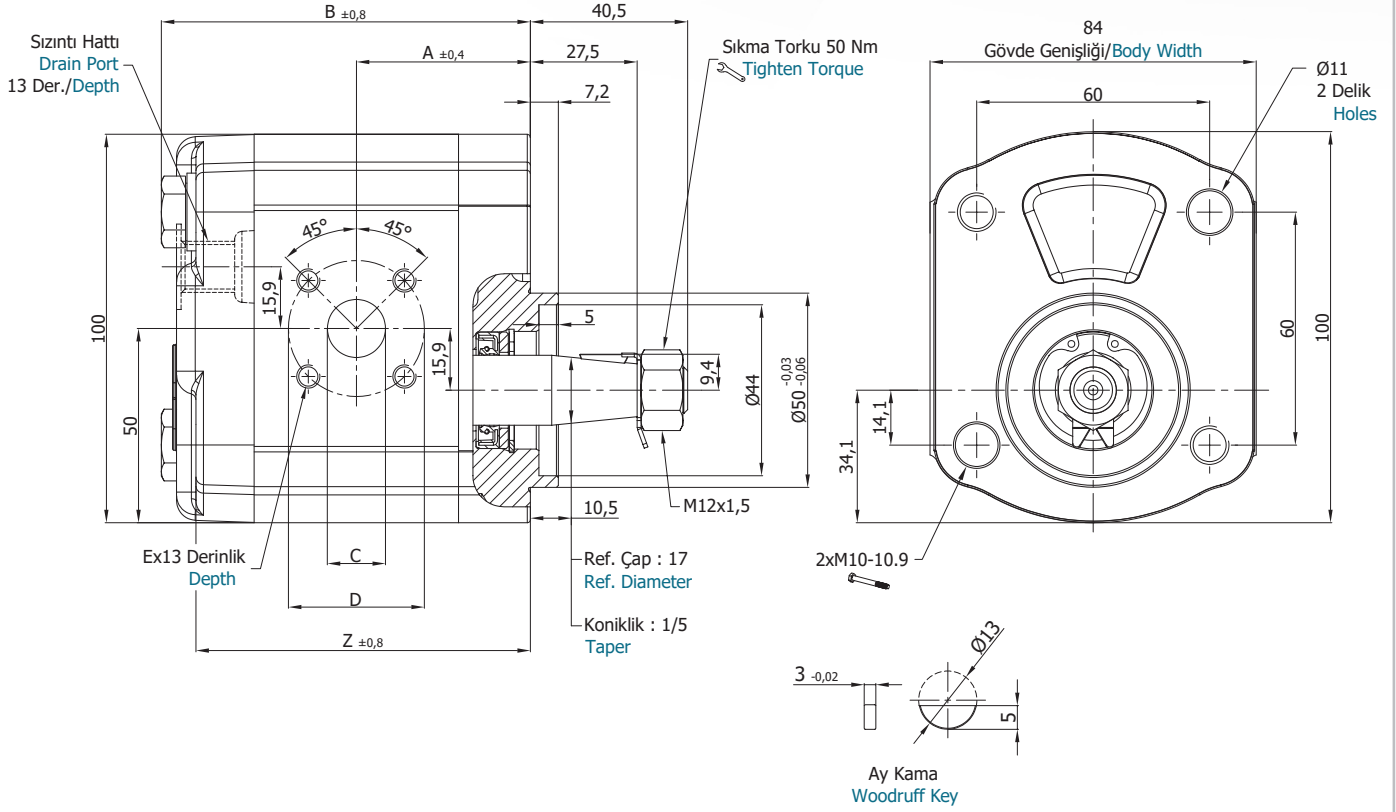
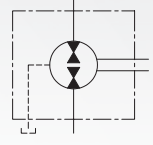

Sızıntı Hattı / Drain Port

G	G 1/4"
U	7/16"-20 UNF
M	M12x1,5

Motor Kodu Motor Code	İletim Hacmi Displacement cm ³ /dev (cm ³ /rev)	Maks. Basınç Max. Pressure (bar)	Maks. Hız Max. Speed d/d (rpm)	A $\pm 0,4$	B $\pm 0,8$	Z $\pm 0,8$	Giriş - Inlet			Çıkış - Outlet			
							C	D	E	C	D	E	
DKM20.040.RBA01EMN	3,9	280	3500	41,7	88,7	79,9	15	35	M6	15	35	M6	
DKM20.060.RBA01EMN	5,9			43,3	91,8	83,0							
DKM20.080.RBA01EMN	8,0			44,8	94,9	86,1							
DKM20.095.RBA01EMN	9,4			46,0	97,2	88,4							
DKM20.115.RBA01EMN	11,4		3000	2500	47,5	100,4	91,6	20	40	M6	20	40	M6
DKM20.140.RBA01EMN	13,9				49,5	104,3	95,5						
DKM20.160.RBA01EMN	16,0				51,0	107,4	98,6						
DKM20.190.RBA01EMN	19,2				59,5	124,5	115,7						
DKM20.220.RBA01EMN	21,9	240	2200	61,8	128,8	120,0	20	40	M6	20	40	M6	
DKM20.250.RBA01EMN	24,8	220		64,3	133,9	125,1							
DKM20.280.RBA01EMN	27,9	200		66,5	138,2	129,4							

B Ön Kapak
Front Cover

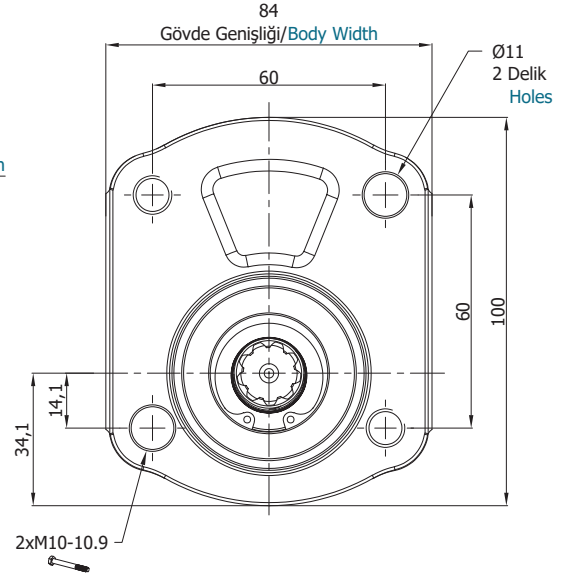
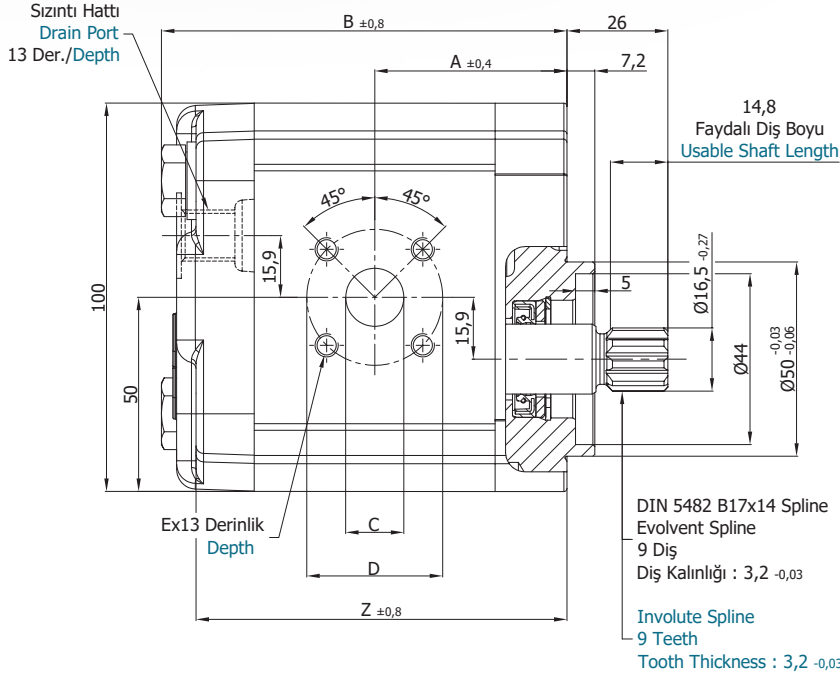
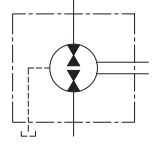
G Şaft Tipi
Shaft Type

Sızıntı Hattı / Drain Port

G	G 1/4"
U	7/16"-20 UNF
M	M12x1,5

Motor Kodu Motor Code	İletim Hacmi Displacement cm ³ /dev (cm ³ /rev)	Maks. Basınç Max. Pressure (bar)	Maks. Hız Max. Speed d/d (rpm)	A $\pm 0,4$	B $\pm 0,8$	Z $\pm 0,8$	Giriş - Inlet			Çıkış - Outlet			
							C	D	E	C	D	E	
DKM20.040.RBG01EMN	3,9	280	3500	41,7	88,7	79,9	15	35	M6	15	35	M6	
DKM20.060.RBG01EMN	5,9			43,3	91,8	83,0							
DKM20.080.RBG01EMN	8,0			44,8	94,9	86,1							
DKM20.095.RBG01EMN	9,4			46,0	97,2	88,4							
DKM20.115.RBG01EMN	11,4		3000	2500	47,5	100,4	91,6	20	40	M6	20	40	M6
DKM20.140.RBG01EMN	13,9				49,5	104,3	95,5						
DKM20.160.RBG01EMN	16,0				51,0	107,4	98,6						
DKM20.190.RBG01EMN	19,2				59,5	124,5	115,7						
DKM20.220.RBG01EMN	21,9	240	2200	61,8	128,8	120,0	20	40	M6	20	40	M6	
DKM20.250.RBG01EMN	24,8	220		64,3	133,9	125,1							
DKM20.280.RBG01EMN	27,9	200		66,5	138,2	129,4							

C Ön Kapak
Front Cover

E Şaft Tipi
Shaft Type

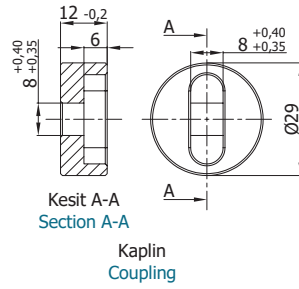
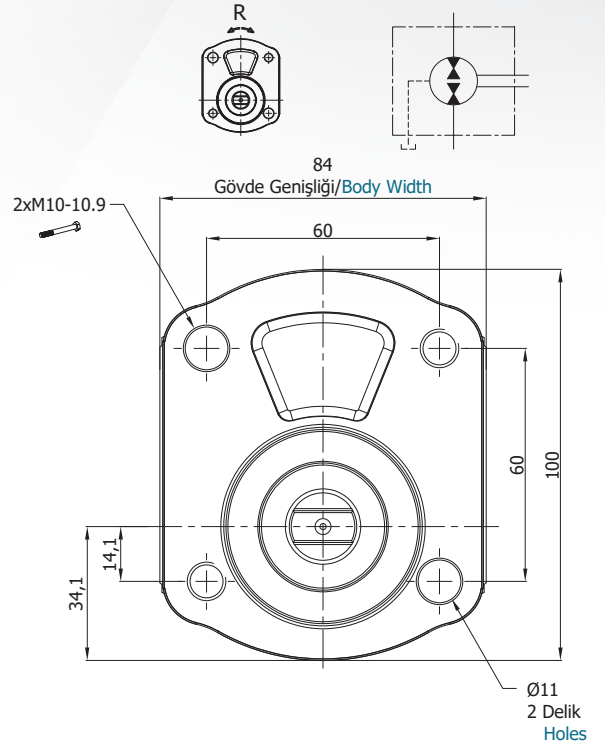
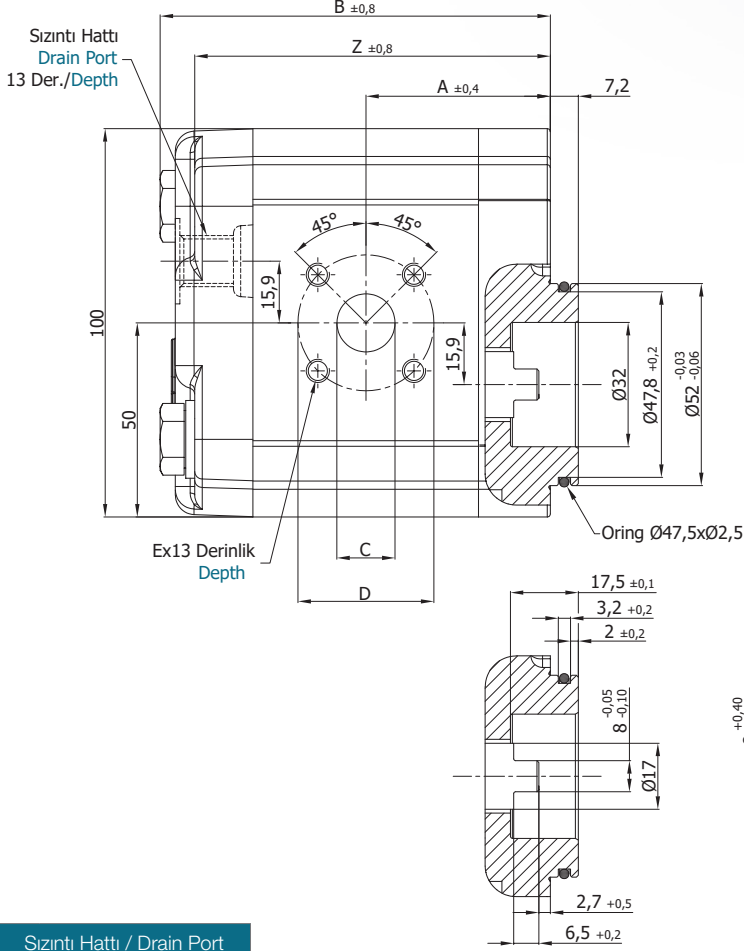

Sızıntı Hattı / Drain Port	
G	G 1/4"
U	7/16"-20 UNF
M	M12x1,5

Motor Kodu Motor Code	İletim Hacmi Displacement cm ³ /dev (cm ³ /rev)	Maks. Basınç Max. Pressure (bar)	Maks. Hız Max. Speed d/d (rpm)	A ±0,4	B ±0,8	Z ±0,8	Giriş - Inlet			Çıkış - Outlet		
							C	D	E	C	D	E
DKM20.040.RCE01EMN	3,9	280	3500	41,7	88,7	79,9	15	35	M6	15	35	M6
DKM20.060.RCE01EMN	5,9			43,3	91,8	83,0						
DKM20.080.RCE01EMN	8,0			44,8	94,9	86,1						
DKM20.095.RCE01EMN	9,4			46,0	97,2	88,4						
DKM20.115.RCE01EMN	11,4		3000	47,5	100,4	91,6						
DKM20.140.RCE01EMN	13,9			49,5	104,3	95,5						
DKM20.160.RCE01EMN	16,0			51,0	107,4	98,6						
DKM20.190.RCE01EMN	19,2			59,5	124,5	115,7						
DKM20.220.RCE01EMN	21,9	240	2500	61,8	128,8	120,0	20	40	M6	20	40	
DKM20.250.RCE01EMN	24,8	220		64,3	133,9	125,1						
DKM20.280.RCE01EMN	27,9	200	2200	66,5	138,2	129,4						

D Ön Kapak
Front Cover

C Şaft Tipi
Shaft Type

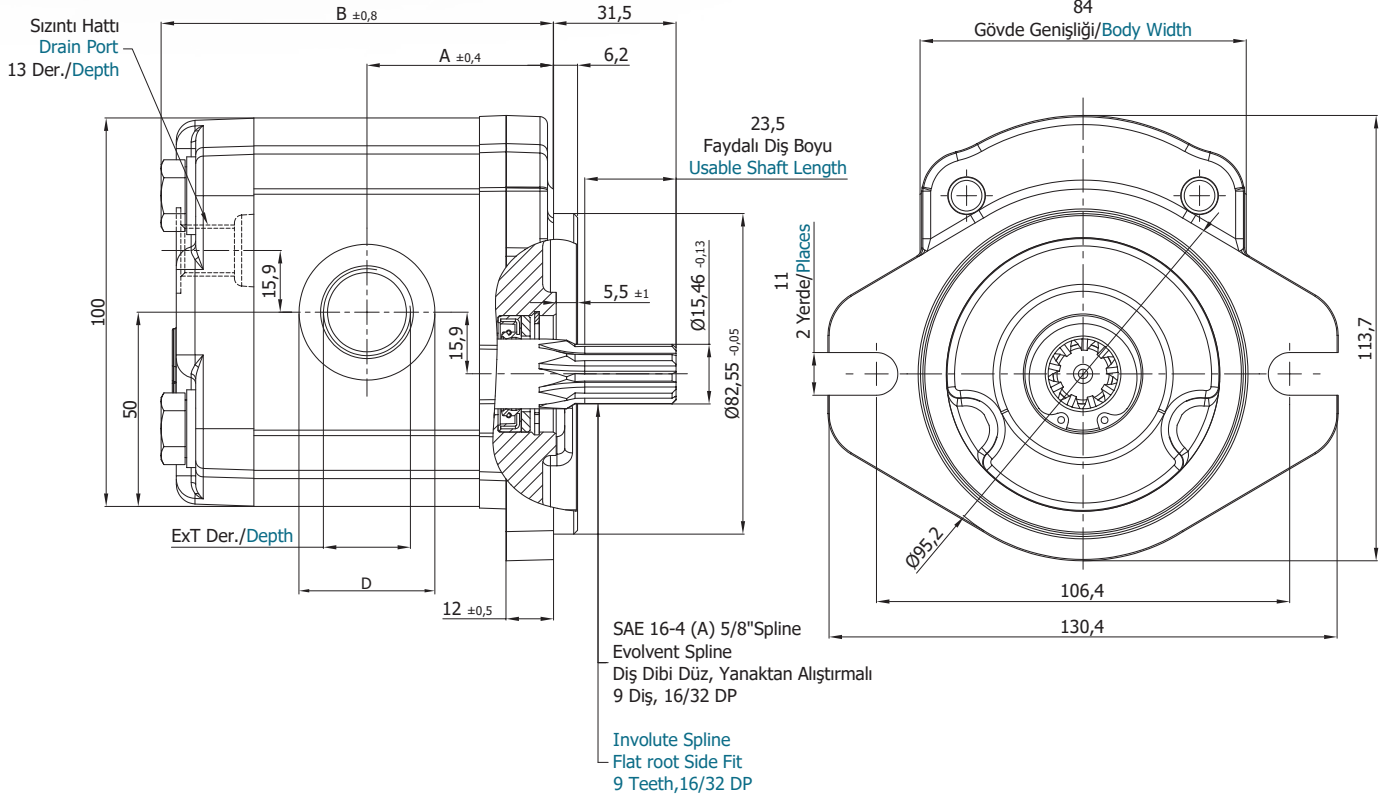
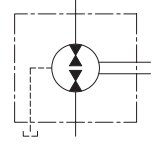
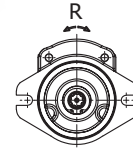

Sızıntı Hattı / Drain Port

G	G 1/4"
U	7/16"-20 UNF
M	M12x1,5

Motor Kodu Motor Code	İletim Hacmi Displacement cm ³ /dev (cm ³ /rev)	Maks. Basınç Max. Pressure (bar)	Maks. Hız Max. Speed d/d (rpm)	A $\pm 0,4$	B $\pm 0,8$	Giriş - Inlet			Çıkış - Outlet		
						E	T	D	E	T	D
DKM20.040.RDC04EUN	3,9	280	3500	42,2	89,2	7/8"-14 UNF-2B	16	35	7/8"-14 UNF-2B	16	35
DKM20.060.RDC04EUN	5,9			43,8	92,3						
DKM20.080.RDC04EUN	8,0			45,3	95,4						
DKM20.095.RDC04EUN	9,4			46,5	97,7						
DKM20.115.RDC04EUN	11,4			48,0	100,9						
DKM20.140.RDC04EUN	13,9		3000	50,0	104,8	1 1/16"-12 UN-2B	19	45	1 1/16"-12 UN-2B	19	45
DKM20.160.RDC04EUN	16,0			51,5	107,9						
DKM20.190.RDC04EUN	19,2			60,0	125,0						
DKM20.220.RDC04EUN	21,9			62,3	129,3						
DKM20.250.RDC04EUN	24,8			64,8	134,4						
DKM20.280.RDC04EUN	27,9	200	2200	67,0	138,7						

D Ön Kapak
Front Cover

H Şaft Tipi
Shaft Type

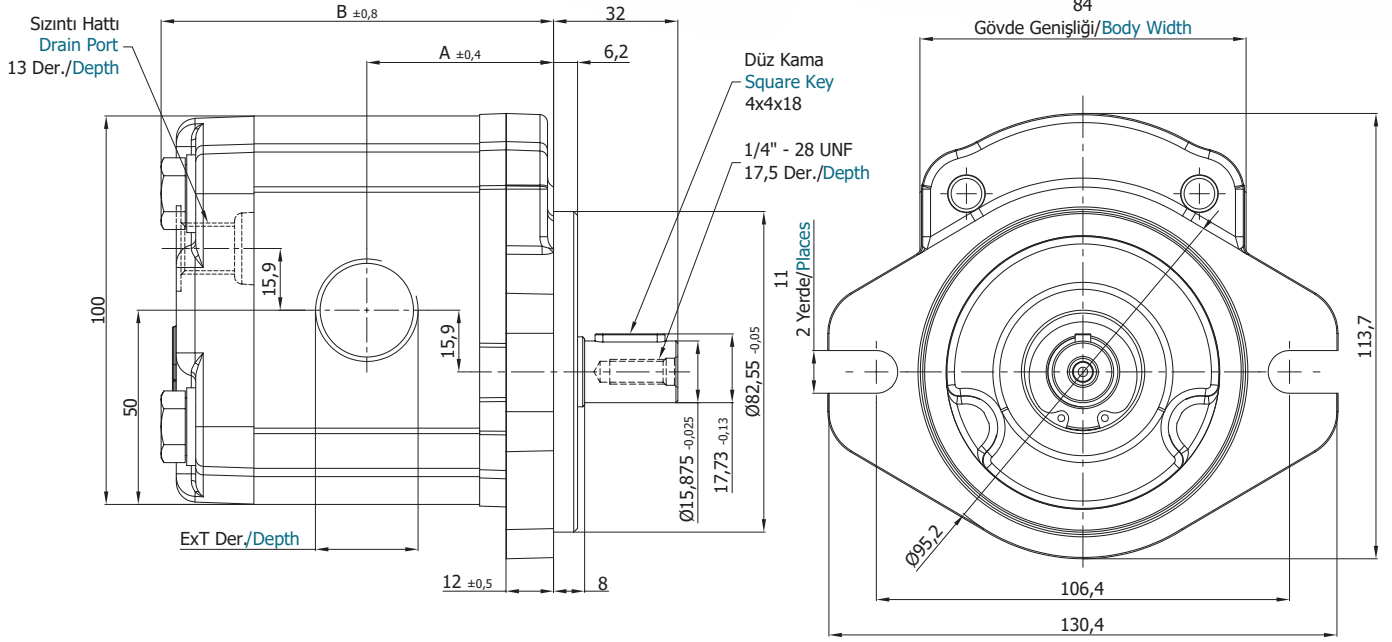
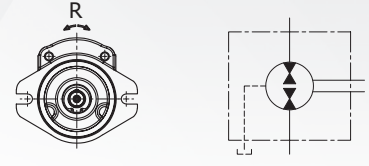

Sızıntı Hattı / Drain Port

G	G 1/4"
U	7/16"-20 UNF
M	M12x1,5

Motor Kodu Motor Code	İletim Hacmi Displacement cm ³ /dev (cm ³ /rev)	Maks. Basınç Max. Pressure (bar)	Maks. Hız Max. Speed d/d (rpm)	A ±0,4	B ±0,8	Giriş - Inlet		Çıkış - Outlet	
						E	T	E	T
DKM20.040.RDH05EGN	3,9	280	3500	42,2	89,2	G 1/2	16	G 1/2	16
DKM20.060.RDH05EGN	5,9			43,8	92,3				
DKM20.080.RDH05EGN	8,0			45,3	95,4				
DKM20.095.RDH05EGN	9,4			46,5	97,7				
DKM20.115.RDH05EGN	11,4		3000	48,0	100,9	G 3/4	16	G 3/4	16
DKM20.140.RDH05EGN	13,9			50,0	104,8				
DKM20.160.RDH05EGN	16,0			51,5	107,9				
DKM20.190.RDH05EGN	19,2			60,0	125,0				
DKM20.220.RDH05EGN	21,9	240	2500	62,3	129,3	G 3/4	16	G 3/4	16
DKM20.250.RDH05EGN	24,8	220		64,8	134,4				
DKM20.280.RDH05EGN	27,9	200		67,0	138,7				

E Ön Kapak
Front Cover

G Şaft Tipi
Shaft Type

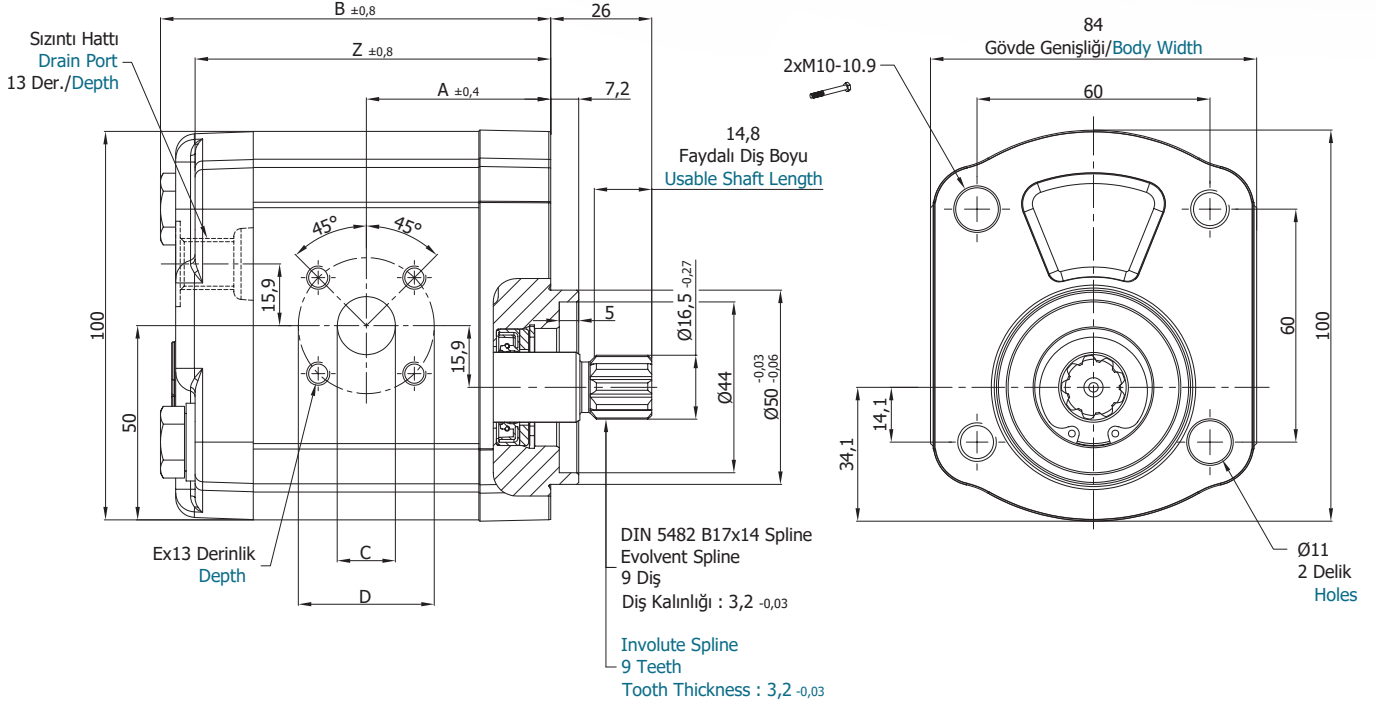
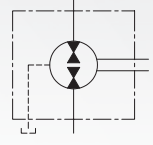

Sızıntı Hattı / Drain Port

G	G 1/4"
U	7/16"-20 UNF
M	M12x1,5

Motor Kodu Motor Code	İletim Hacmi Displacement cm ³ /dev (cm ³ /rev)	Maks. Basınç Max. Pressure (bar)	Maks. Hız Max. Speed d/d (rpm)	A ±0,4	B ±0,8	Z ±0,8	Giriş - Inlet			Çıkış - Outlet			
							C	D	E	C	D	E	
DKM20.040.REG01EGN	3,9	280	3500	41,7	88,7	79,9	15	35	M6	15	35	M6	
DKM20.060.REG01EGN	5,9			43,3	91,8	83,0							
DKM20.080.REG01EGN	8,0			44,8	94,9	86,1							
DKM20.095.REG01EGN	9,4			46,0	97,2	88,4							
DKM20.115.REG01EGN	11,4		3000	2500	47,5	100,4	91,6	20	40	M6	20	40	M6
DKM20.140.REG01EGN	13,9				49,5	104,3	95,5						
DKM20.160.REG01EGN	16,0				51,0	107,4	98,6						
DKM20.190.REG01EGN	19,2				59,5	124,5	115,7						
DKM20.220.REG01EGN	21,9	240	2200	61,8	128,8	120,0	20	40	M6	20	40	M6	
DKM20.250.REG01EGN	24,8	220		64,3	133,9	125,1							
DKM20.280.REG01EGN	27,9	200		66,5	138,2	129,4							

G Ön Kapak
Front Cover

G Şaft Tipi
Shaft Type

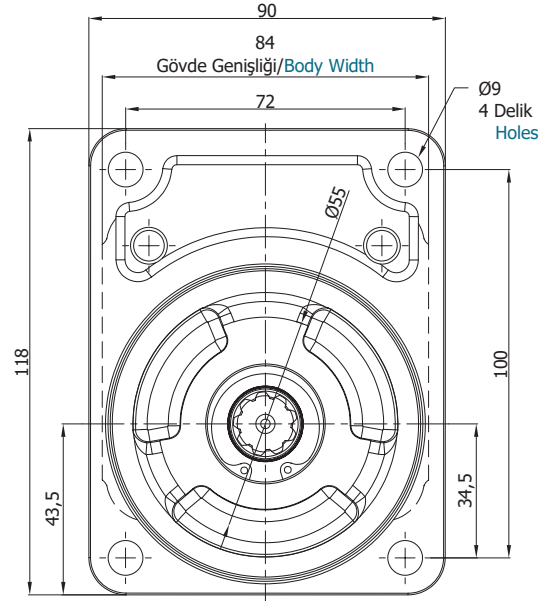
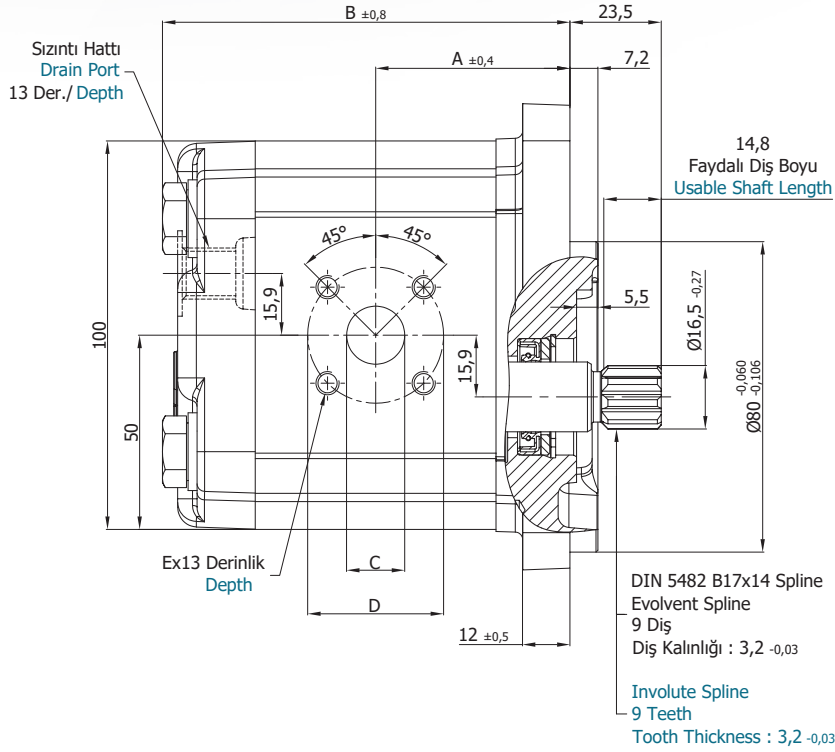
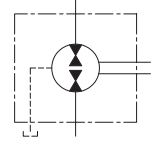
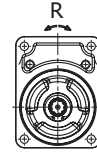

Sızıntı Hattı / Drain Port

G	G 1/4"
U	7/16"-20 UNF
M	M12x1,5

Motor Kodu Motor Code	İletim Hacmi Displacement cm ³ /dev (cm ³ /rev)	Maks. Basınç Max. Pressure (bar)	Maks. Hız Max. Speed d/d (rpm)	A $\pm 0,4$	B $\pm 0,8$	Giriş - Inlet			Çıkış - Outlet		
						C	D	E	C	D	E
DKM20.040.RGG01EMN	3,9	280	3500	42,2	89,2	15	35	M6	15	35	M6
DKM20.060.RGG01EMN	5,9			43,8	92,3						
DKM20.080.RGG01EMN	8,0			45,3	95,4						
DKM20.095.RGG01EMN	9,4			46,5	97,7						
DKM20.115.RGG01EMN	11,4		3000	48,0	100,9	20	40	M6	20	40	M6
DKM20.140.RGG01EMN	13,9			50,0	104,8						
DKM20.160.RGG01EMN	16,0			51,5	107,9						
DKM20.190.RGG01EMN	19,2			60,0	125,0						
DKM20.220.RGG01EMN	21,9	240	2500	62,3	129,3	20	40	M6	20	40	M6
DKM20.250.RGG01EMN	24,8	220		64,8	134,4						
DKM20.280.RGG01EMN	27,9	200		2200	67,0						

G Ön Kapak
Front Cover

L Şaft Tipi
Shaft Type

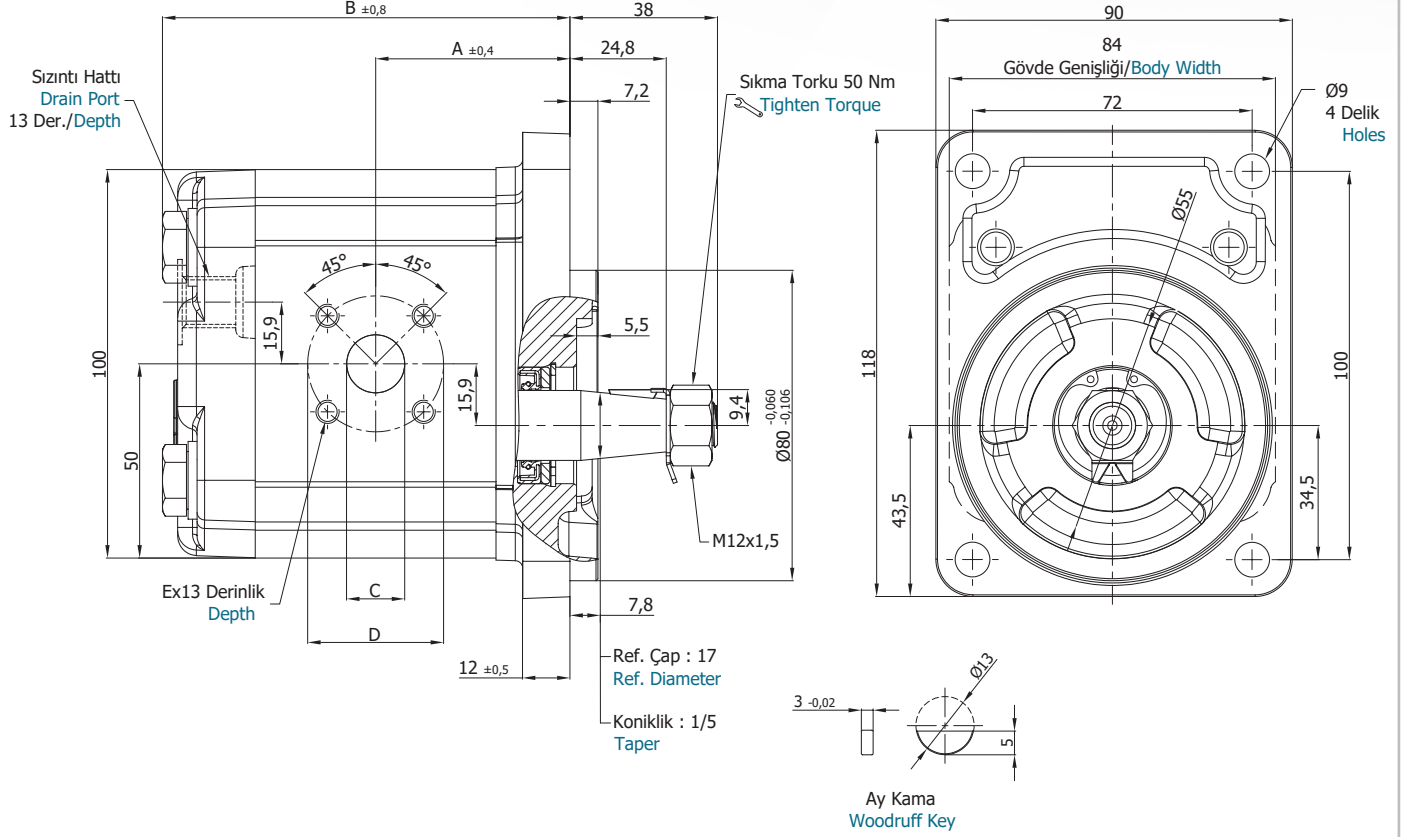
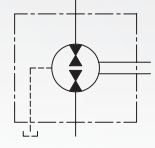

Sızıntı Hattı / Drain Port

G	G 1/4"
U	7/16"-20 UNF
M	M12x1,5

Motor Kodu Motor Code	İletim Hacmi Displacement cm ³ /dev (cm ³ /rev)	Maks. Basınç Max. Pressure (bar)	Maks. Hız Max. Speed d/d (rpm)	A ±0,4	B ±0,8	Giriş - Inlet			Çıkış - Outlet		
						C	D	E	C	D	E
DKM20.040.RGL01EMN	3,9	280	3500	42,2	89,2	15	35	M6	15	35	M6
DKM20.060.RGL01EMN	5,9			43,8	92,3						
DKM20.080.RGL01EMN	8,0			45,3	95,4						
DKM20.095.RGL01EMN	9,4			46,5	97,7						
DKM20.115.RGL01EMN	11,4		3000	48,0	100,9						
DKM20.140.RGL01EMN	13,9			50,0	104,8						
DKM20.160.RGL01EMN	16,0			51,5	107,9						
DKM20.190.RGL01EMN	19,2			60,0	125,0						
DKM20.220.RGL01EMN	21,9	240	2500	62,3	129,3	20	40		20	40	
DKM20.250.RGL01EMN	24,8	220		64,8	134,4						
DKM20.280.RGL01EMN	27,9	200		2200	67,0						138,7

G Ön Kapak
Front Cover

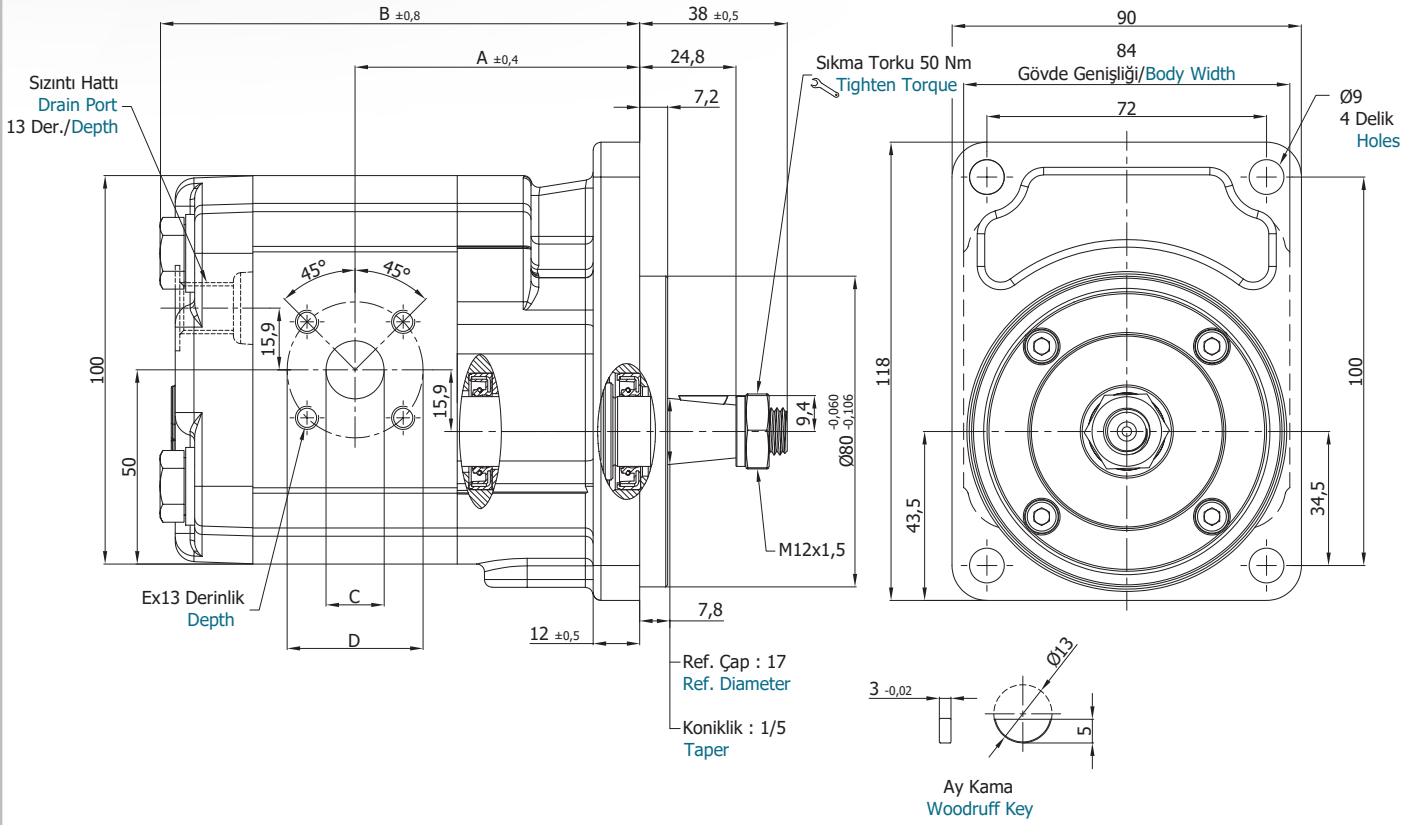
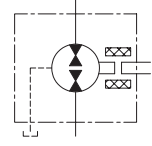
L Şaft Tipi
Shaft Type

Sızıntı Hattı / Drain Port

G	G 1/4"
U	7/16"-20 UNF
M	M12x1,5

Motor Kodu Motor Code	İletim Hacmi Displacement cm ³ /dev (cm ³ /rev)	Maks. Basınç Max. Pressure (bar)	Maks. Hız Max. Speed d/d (rpm)	A ±0,4	B ±0,8	Giriş - Inlet			Çıkış - Outlet		
						C	D	E	C	D	E
DKM20.040.RGL01EGO8N	3,9	280	3500	70,2	117,2	15	35	M6	15	35	M6
DKM20.060.RGL01EGO8N	5,9			71,8	120,3						
DKM20.080.RGL01EGO8N	8,0			73,3	123,4						
DKM20.095.RGL01EGO8N	9,4			74,5	125,7						
DKM20.115.RGL01EGO8N	11,4		76,0	128,9	20	40	20	40			
DKM20.140.RGL01EGO8N	13,9		78,0	132,8							
DKM20.160.RGL01EGO8N	16,0		79,5	135,9							
DKM20.190.RGL01EGO8N	19,2		88,0	153,0							
DKM20.220.RGL01EGO8N	21,9	240	2500	90,3	157,3	20	40	20	40		
DKM20.250.RGL01EGO8N	24,8	220	92,8	162,4							
DKM20.280.RGL01EGO8N	27,9	200	2200	95,0	166,7						

H Ön Kapak
Front Cover

K Şaft Tipi
Shaft Type

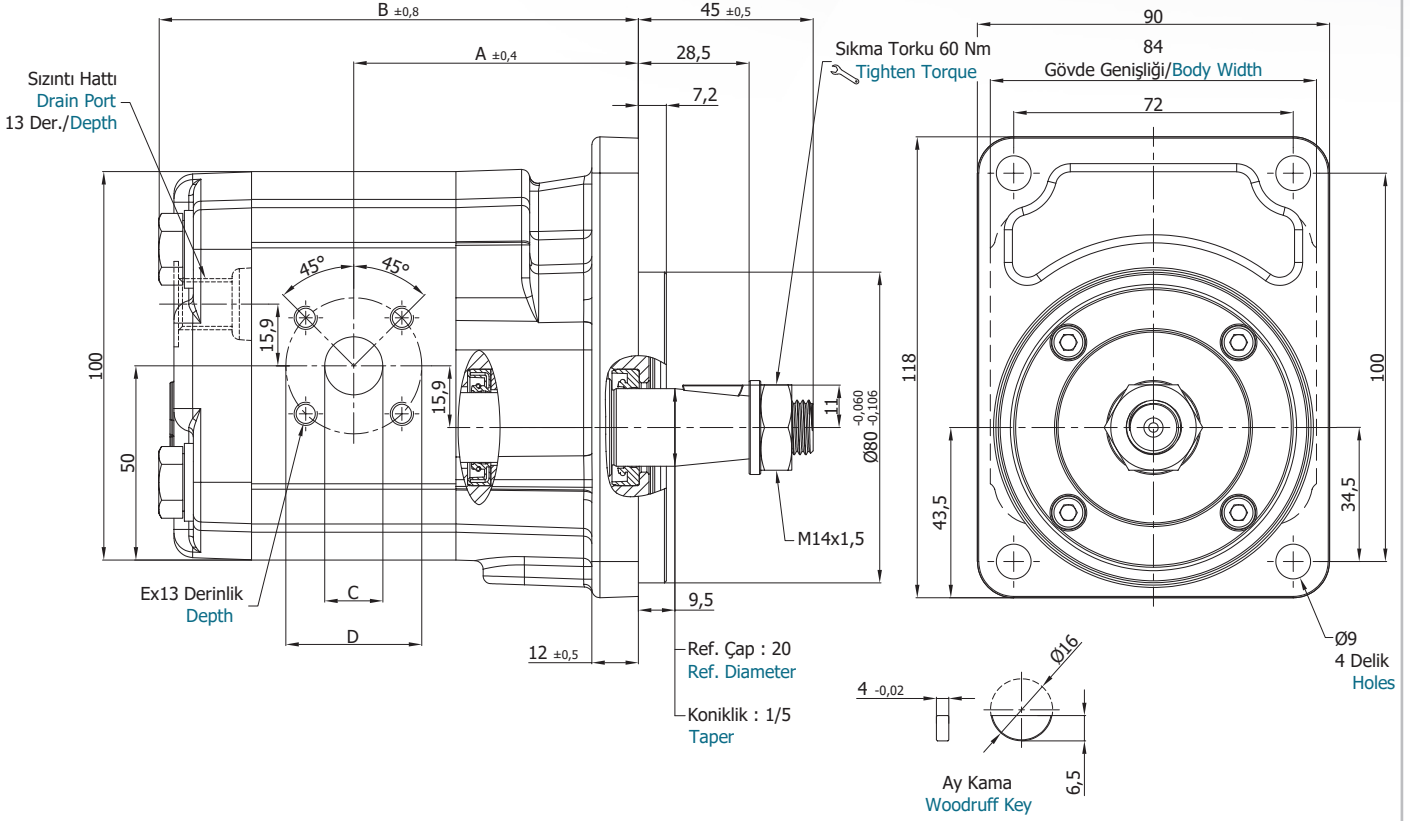
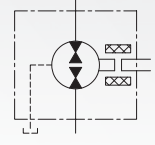

Sızıntı Hattı / Drain Port

G	G 1/4"
U	7/16"-20 UNF
M	M12x1,5

Motor Kodu Motor Code	İletim Hacmi Displacement cm ³ /dev (cm ³ /rev)	Maks. Basınç Max. Pressure (bar)	Maks. Hız Max. Speed d/d (rpm)	A ±0,4	B ±0,8	Giriş - Inlet			Çıkış - Outlet		
						C	D	E	C	D	E
DKM20.040.RHK01EGO8N	3,9	280	3500	70,2	117,2	15	35	M6	15	35	M6
DKM20.060.RHK01EGO8N	5,9			71,8	120,3						
DKM20.080.RHK01EGO8N	8,0			73,3	123,4						
DKM20.095.RHK01EGO8N	9,4			74,5	125,7						
DKM20.115.RHK01EGO8N	11,4		76,0	128,9	20	40	M6	20	40		
DKM20.140.RHK01EGO8N	13,9		78,0	132,8							
DKM20.160.RHK01EGO8N	16,0		79,5	135,9							
DKM20.190.RHK01EGO8N	19,2		88,0	153,0							
DKM20.220.RHK01EGO8N	21,9	240	2500	90,3	157,3	20	40	M6	20	40	
DKM20.250.RHK01EGO8N	24,8	220		92,8	162,4						
DKM20.280.RHK01EGO8N	27,9	200	2200	95,0	166,7						

G Ön Kapak
Front Cover

L Şaft Tipi
Shaft Type

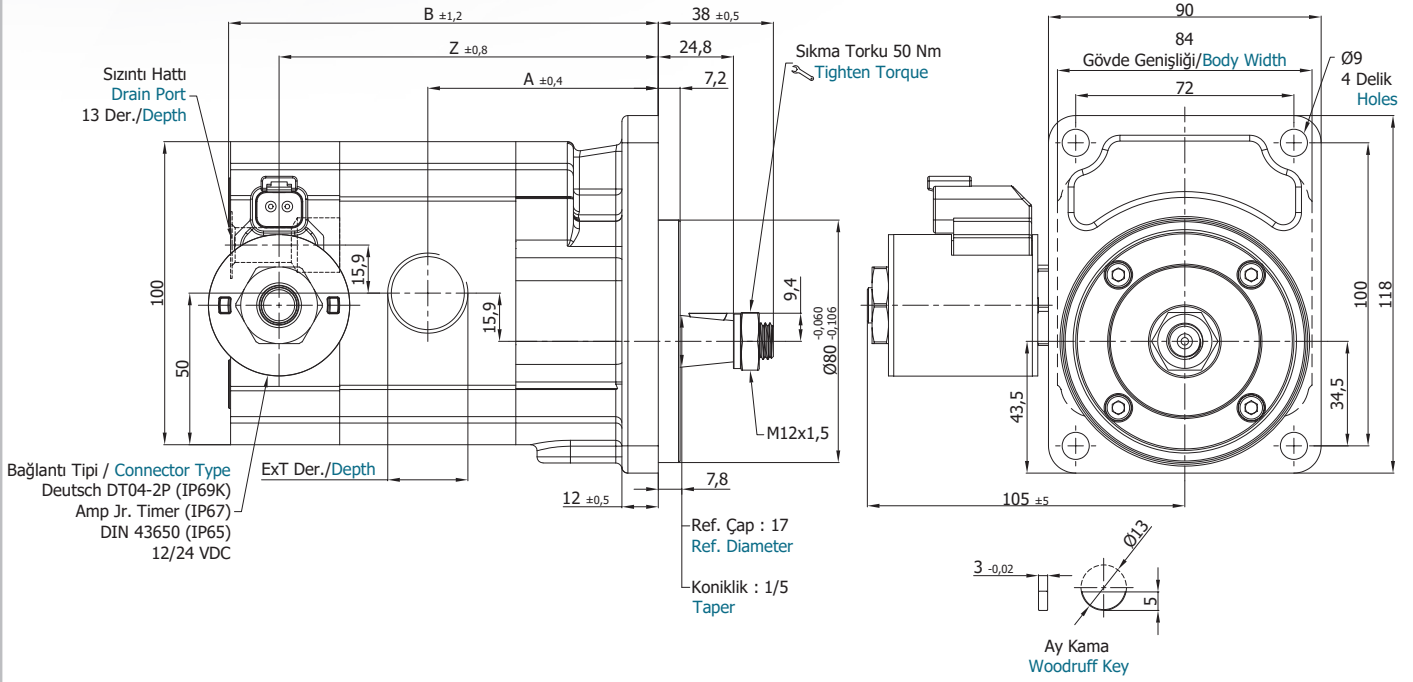
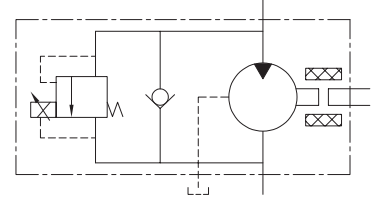
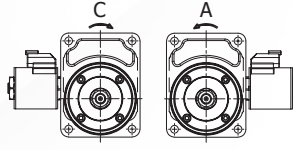

Sızıntı Hattı / Drain Port

G G 1/4"

U 7/16"-20 UNF

M M12x1,5

NOT: Bu motor kombinasyonu, elektronik bağlantılı, oransal basınç emniyet valfi ve antikavitasyon çek valf ile hidrolik fan motoru uygulamaları için idealdir.

NOTE: This motor combination is ideal for hydraulic fan drive applications with an electronically connector, proportional pressure relief valve and anti-cavitation check valve.

Motor Kodu Motor Code	İletim Hacmi Displacement cm ³ /dev (cm ³ /rev)	Maks. Basınç Max. Pressure (bar)	Maks. Hız Max. Speed d/d (rpm)	A $\pm 0,4$	B $\pm 1,2$	Z $\pm 0,8$	Giriş - Inlet		Çıkış - Outlet					
							E	T	E	T				
DKM20.040.A/CGL05BO8GN	3,9	280	3500	70,2	130,2	113,4	G 1/2	16	G 1/2	16				
DKM20.060.A/CGL05BO8GN	5,9			71,8	133,3	116,5								
DKM20.080.A/CGL05BO8GN	8,0			73,3	136,4	119,6								
DKM20.095.A/CGL05BO8GN	9,4			74,5	138,7	121,9								
DKM20.115.A/CGL05BO8GN	11,4			76,0	141,9	125,1								
DKM20.140.A/CGL05BO8GN	13,9			78,0	145,8	129,0								
DKM20.160.A/CGL05BO8GN	16,0			79,5	149,0	132,2								
DKM20.190.A/CGL05BO8GN	19,2			88,0	166,0	149,2								
DKM20.220.A/CGL05BO8GN	21,9			240	2500	90,3					170,3	153,5	G 3/4	G 3/4
DKM20.250.A/CGL05BO8GN	24,8					92,8					175,4	158,6		
DKM20.280.A/CGL05BO8GN	27,9	95,0	179,7			162,9								



Ascend to Greater Value
Birlikte Daha Yüksekçe

 **blue**
ascend
hydraulics

blueascend.com

